

# Bulletin 1606 Switched Mode Power Supplies

Catalog Number: 1606-XLS240-UPSD

## Index

1. General Description .....	1	16. Reliability .....	15
2. Specification Quick Reference .....	1	17. EMC .....	16
3. Catalog Numbers .....	1	18. Environment .....	17
4. Certification Marks .....	1	19. Protection Features .....	17
5. Input .....	3	20. Safety .....	18
6. Output in Normal Mode .....	4	21. Certifications .....	18
7. Output in Buffer Mode .....	5	22. Environmental Compliance .....	19
8. Battery Input .....	7	23. Physical Dimensions and Weight .....	19
9. Buffer Time .....	8	24. Installation Notes .....	20
10. Efficiency and Power Losses .....	10	25. Accessories .....	21
11. Functional Diagram .....	10	26. Application Notes .....	22
12. Check Wiring and Battery Quality Tests .....	11	26.1. Battery Replacement Intervals .....	22
13. Relay Contacts and Inhibit Input .....	12	26.2. Parallel and Serial Use .....	23
14. Front Side User Elements .....	13	26.3. Using the Inhibit Input .....	24
15. Terminals and Wiring .....	14	26.4. Troubleshooting .....	24

## Terminology and Abbreviations

- **DC UPS**—Uninterruptible power supply with DC input.
- **Normal mode**—Describes a condition where the battery is charged, the input voltage is in range and the output is loaded within the allowed limits.
- **Buffer mode**—Describes a condition where the input voltage is below the transfer threshold level, the unit is running on battery (buffering) and the output is loaded within the allowed limits.
- **Charging mode**—Describes a condition where the battery is being charged, the input voltage is in range and the output is loaded within the allowed limits.
- **Inhibit mode**—Describes a condition where buffering is disabled intentionally by using the inhibit input of the DC UPS (e.g. for service actions or to save battery capacity).
- **Buffer time**—Equivalent to the term “hold-up time.”
- **T.b.d.**—To be defined, value or description will follow later.

LISTEN.  
THINK.  
SOLVE.®



## DC-UPS, Dual Output

- 24V DC-UPS With an Additional 12V Output for Various Applications
- Only One 12V Battery Required
- Stable Output Voltage in Buffer Mode
- Superior Battery Management for Longest Battery Life
- Comprehensive Diagnostic and Monitoring Functions
- Replace Battery Signal Included
- Electronically Overload and Short Circuit Protected
- 50% Power Reserves
- 3 Year Warranty

### 1. Description

The 1606-XLS240-UPSD uninterruptible power supply (UPS) controller along with a standard 24V power supply and one 12V battery can bridge power failures or voltage fluctuations. This unit can supply and bridge both a 24V load as well as a 12V load at the same time. The 12V is generated by a DC/DC converter from the 24V output. Therefore, systems that use 24V control circuits and require 12V for e.g. remote radio telemetry can be supplied with only one 1606-XLS240-UPSD DC-UPS controller.

The DC-UPS includes a professional battery management system which charges and monitors the battery to achieve the longest battery service life as well as many diagnostic functions that ensure a reliable operation of the entire system.

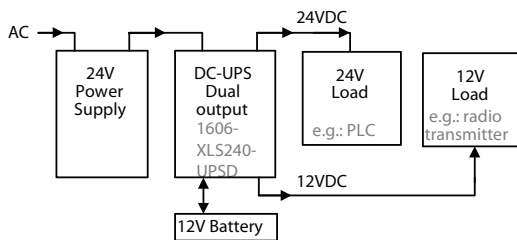

### 2. Specification Quick Reference

Input voltage	24Vdc 22.5-30Vdc	Nominal Input range
Output voltage (normal mode)	0.23V lower as input voltage 12V	Typ., 24V output 12V output
Output voltage (buffer mode)	22.25V 12V	24V output at 10A 12V output at 5A
Output current (normal mode)	0 - 15A 0 - 5A	24V output 12V output
Output current (buffer mode)	0 - 10A 10 - 15A for 5s 0 - 5A	24V output 24V output 12V output
Total output power	360W 240W	Normal mode Buffer mode
Allowed batteries	3.9Ah to 40Ah	VRLA lead acid
Temperature range	-25 to +70°C	Operational
Derating	6W/°C	+50 to +70°C
Dimensions	49x124x117mm	WxHxD
Buffer time	typ. 6'30"	7Ah battery module 24V 7A, 12V 5A
	typ. 54'	26Ah module 24V 7A, 12V 5A

### 3. Catalog Numbers

DC-UPS	1606-XLS240-UPSD	24V and 12V output
Accessories	1606-XLSBATASSY1	Battery module 12V 7Ah
	1606-XLSBATBR1	Mounting kit w/o battery
	1606-XLSBATASSY2	Battery module 12V 26Ah
	1606-XLSBARBR2	Mounting kit w/o battery
	1606-XLB	Panel/Wall mount bracket

### 4. Certification Marks



Marine RINA



GOST R



C-TICK

All parameters are specified at an input voltage of 24V, 10A output load, 25°C ambient and after a 5 minutes run-in time unless noted otherwise.

It is assumed that the input power source can deliver a sufficient output current.

Rockwell Automation Publication 1606-RM017A-EN-P — February 2014

## Intended Use

- This device is designed for installation in an enclosure and is intended for the general professional use such as in industrial control, office, communication, and instrumentation equipment.
- Do not use this power supply in aircraft, trains, nuclear equipment or similar systems where malfunction may cause severe personal injury or threaten human life.
- This device is designed for use in hazardous (pending), non-hazardous, ordinary or unclassified locations.

## 5. Input

Input voltage	nom.	DC 24V	
Input voltage ranges	nom.	22.5 to 30Vdc 30 to 35Vdc 35Vdc  0 to 22.5Vdc	Continuous operation, see Fig. 5-1 Temporarily allowed, no damage to the DC-UPS *) Absolute maximum input voltage with no damage to the DC-UPS The DC-UPS switches into buffer mode and delivers output voltage from the battery if the input was above the turn-on level before and all other buffer conditions are fulfilled.
Allowed input voltage ripple	max.	1.5Vpp 1Vpp	Bandwidth <400Hz Bandwidth 400Hz to 1kHz
Allowed voltage between input and earth (ground)	max.	60Vdc or 42.4Vac	
Turn-on voltage	typ.	22.8Vdc	The output does not switch on if the input voltage does not exceed this level.
	max.	23Vdc	
Input current **)	typ.	140mA	Internal current consumption for the DC-UPS
	typ.	1.1A	Current consumption for battery charging in constant current mode at 24V input (see Fig 8-2). ***)
External capacitors on the input		No limitation	

\*) The DC-UPS shows "Check Wiring" with the red LED and buffering is not possible.

\*\*) The total input current is the sum of the output current, the current which is required to charge the battery during the charging process and the current which is needed to supply the DC-UPS itself. See also Fig. 5-2. This calculation does not apply in overload situations where the DC-UPS limits the output current, therefore see Fig. 5-3.

\*\*\*) Please note: This is the input current and not the current which flows into the battery during charging. The battery current can be found in section 8.

Fig. 5-1 Input voltage range

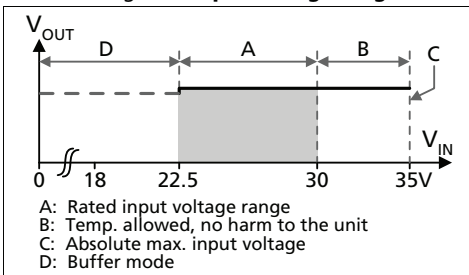
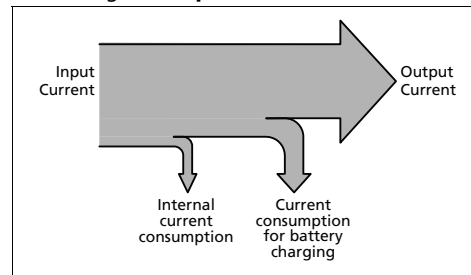

Fig. 5-2 Input current, definitions



### Electric output current limitation

The DC-UPS is equipped with an electronic output current limitation. This current limitation works in a switching mode which reduces the power losses and heat generation to a minimum. As a result, the output voltage drops since there is not enough current to support the load. A positive effect of the current limitation in switching mode is that the input current goes down despite an increase in the output current resulting in less stress for the supplying source. Fig 5-3 shows the behavior when the 12V is not loaded. Power which is taken out from the 12V reduces the power on the 24V side.

Fig. 5-3 Input current and output voltage vs. output current, typ. (battery fully charged)

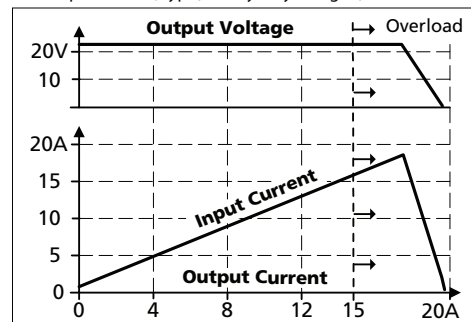

All parameters are specified at an input voltage of 24V, 10A output load, 25°C ambient and after a 5 minutes run-in time unless noted otherwise. It is assumed that the input power source can deliver a sufficient output current.

## 6. Output in Normal Mode

The total output power of 360W can be shifted dynamically between the two outputs.

### 24V Output:

Output voltage	nom.	DC 24V	The output voltage follows the input voltage reduced by the input to output voltage drop.
Voltage drop between input and output	max.	0.3V	At 10A output current, see Fig. 6-1 for typical values
	max.	0.45V	At 15A output current, see Fig. 6-1 for typical values
Ripple and noise voltage	max.	20mVpp	20Hz to 20MHz, 50Ohm *)
Output current	nom.	0 – 15A	Continuously allowed, lower if the 12V output is loaded.
	min.	12.3A	Output if 12V output is loaded with 5A.
Short-circuit current	min.	17.9A	Load impedance 100mOhm, see Fig. 6-2 for typical values. The 12V output is off during an overload or short on the 24V.
	max.	21A	
Capacitive and inductive loads		No limitation	

### 12V Output:

Output voltage	nom.	DC 12V	
Output voltage tolerance		±2%	
Ripple and noise voltage	typ.	30mVpp	20Hz to 20MHz, 50Ohm *)
Output current	nom.	0 - 5A	Continuously allowed, may be lower if the 24V output is loaded more than 12.3A
	min.	4A	Load impedance 100mOhm, see Fig. 7-5. for typical values.
Short-circuit current	min.	4A	Load impedance 100mOhm, see Fig. 7-5. for typical values.
	max.	5.5A	The 24V output is on during an overload or short on the 12V.
Capacitive and inductive loads		No limitation	

\*) This figure shows the ripple and noise voltage which is generated by the DC-UPS. The ripple and noise voltage may be higher if the supplying source has a higher ripple and noise voltage.

Fig. 6-1 Input to output voltage drop, typ.

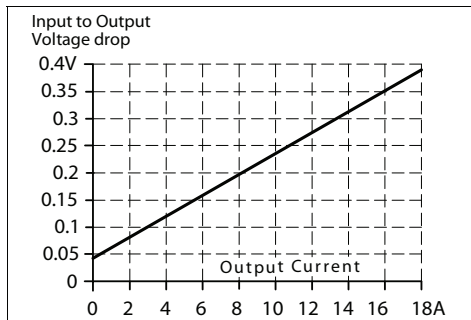
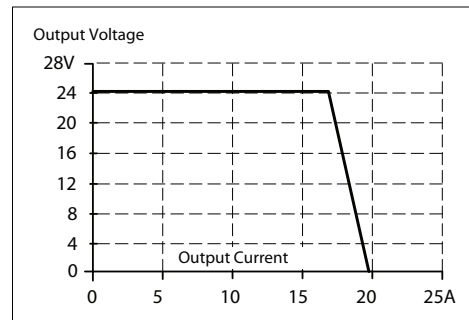

Fig. 6-2 Output voltage vs, output current in normal mode at 24V input, typ.



All parameters are specified at an input voltage of 24V, 10A output load, 25°C ambient and after a 5 minutes run-in time unless noted otherwise.

It is assumed that the input power source can deliver a sufficient output current.

Rockwell Automation Publication 1606-RM017A-EN-P — February 2014

## 7. Output in Buffer Mode

If the input voltage falls below the transfer threshold level, the DC-UPS starts buffering without any interruption or voltage dips. The transfer threshold level is typically 80mV higher than the 24V output voltage in buffer mode. Buffering is possible even if the battery is not fully charged.

### 24V Output

Output voltage	nom.	DC 24V 22.45V 22.25V	Output is stabilized and independent from battery voltage. ±1%, at no load, ±1%, at 10A output current
Ripple and noise voltage	max.	20mVpp	20Hz to 20MHz, 50Ohm
Output current	nom.	0 - 10A 10 - 15A	Continuously allowed, 12V output not loaded. *) 12V output not loaded.
	min.	7.0A	If 12V output is loaded with 5A.
Short-circuit current	min.	17.9A	Load impedance 100mOhm **); the 12V output is off during an overload or short on the 24V.
	max.	21A	

### 12V Output

Output voltage	nom.	DC 12V	Output is stabilized and independent from battery voltage.
Output voltage tolerance		±2%	
Ripple and noise voltage	typ.	30mVpp	20Hz to 20MHz, 50Ohm ;
Output current	nom.	0 - 5A	Continuously allowed, may be lower if the 24V output is loaded more than 7.0A
Short-circuit current	min.	4A	Load impedance 100mOhm, see Fig. 7-5 for typical values. Continuous constant; the 24V output is on during an overload or short on the 12V as long as the battery delivers current.
	max.	5.5A	

\*) If the output current is in the range between 10A and 15A (Bonus Power) for longer than 5s, a hardware-controlled reduction of the maximal output current to 10A occurs. If the 10A are not sufficient to maintain the 24V, buffering stops at both outputs after another 5s. Buffering is possible again as soon as the input voltage recovers.

\*\*\*) If the nominal output voltage cannot be maintained in buffer mode, the DC-UPS switches off after 5s to save battery capacity.

Fig. 7-1 Buffering transition, definition

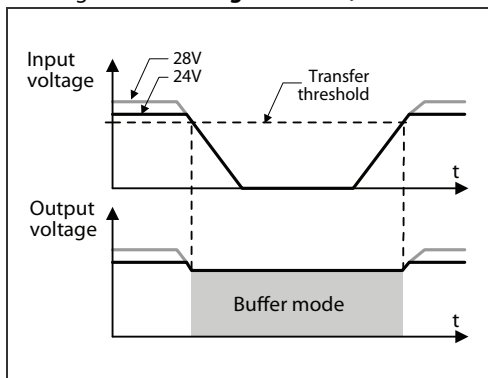
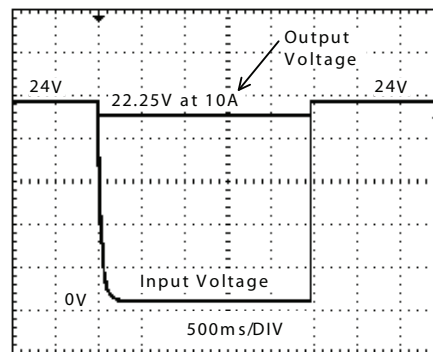

Fig. 7-2 Transfer behavior, typ.



All parameters are specified at an input voltage of 24V, 10A output load, 25°C ambient and after a 5 minutes run-in time unless noted otherwise.

It is assumed that the input power source can deliver a sufficient output current.

Rockwell Automation Publication 1606-RM017A-EN-P — February 2014

Fig. 7-3 Available output current in buffer mode

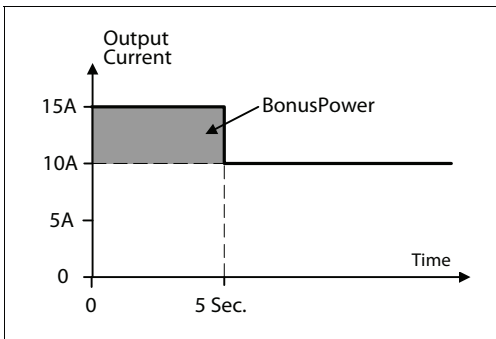

Fig. 7-4 24V Output voltage vs. output current in buffer mode, typ.

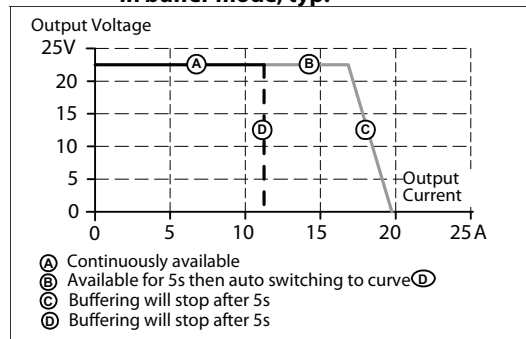
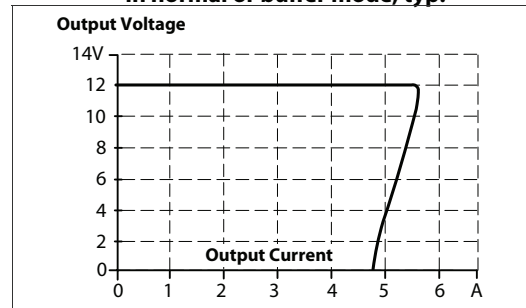

Fig. 7-5 12V Output voltage vs. output current in normal or buffer mode, typ.



All parameters are specified at an input voltage of 24V, 10A output load, 25°C ambient and after a 5 minutes run-in time unless noted otherwise.

It is assumed that the input power source can deliver a sufficient output current.

## 8. Battery Input

The DC-UPS requires one 12V VRLA battery to buffer the 24V and 12V output.

Battery voltage	nom.	DC 12V	Use one maintenance-free 12V VRLA lead acid battery or one battery module which is listed in the Accessories section.
Battery voltage range		9.0 – 15.0V	Continuously allowed, except deep discharge protection
	max.	35Vdc	Absolute maximum voltage with no damage to the unit
	typ.	7.4V	Above this voltage level battery charging is possible.
Allowed battery sizes	min.	3.9Ah	
	max.	40Ah	
Internal battery resistance	max.	100mOhm	See individual battery datasheets for this value
Battery charging method		CC-CV	Constant current, constant voltage mode
Battery charging current (CC-mode)	nom.	1.5A	Independent from battery size,
	max.	1.7A	Corresponding 24V input current see Fig. 8-2
End-of-charge-voltage (CV-mode)		13.4-13.9V	Adjustable, see section 14
Battery charging time	typ.	5h *)	For a 7Ah battery
	typ.	17h *)	For a 26Ah battery
Battery discharging current **)	typ.	21A	Buffer mode, 240W output, 11.5V on the battery terminal of the DC-UPS, see Fig. 8-1 for other parameters
	typ.	0.3A	Buffer mode, 0A output current
	max.	50µA	At no input, buffering had switched off, all LEDs are off
	typ.	310mA	At no input, buffering had switched off, yellow LED shows "buffer time expired" (max. 15 minutes)
Deep discharge protection ***)	typ.	10.5V	At 0% output load
	typ.	9.0V	At 100% output load

\*) The charging time depends on the duration and load current of the last buffer event. The numbers in the table represent a fully discharged battery. A typical figure for a buffer current of 10A at 24V output is 3h 20Min. for a 7Ah battery.

\*\*) The current between the battery and the DC-UPS is more than twice the 24V output current. This is caused by boosting the 12V battery voltage to a 24V level. This high current requires large wire gauges and short cable length for the longest possible buffer time. The higher the resistance of the connection between the battery and the DC-UPS, the lower the voltage on the battery terminals which increases the discharging current. See also section 24 for additional installation instructions.

\*\*\*) To ensure longest battery lifetime, the DC-UPS has a battery deep discharge protection feature included. The DC-UPS stops buffering when the voltage on the battery terminals of the DC-UPS fall below a certain value.

Fig. 8-1 **Battery discharging current vs. 24V output current, typ. (12V not loaded)**

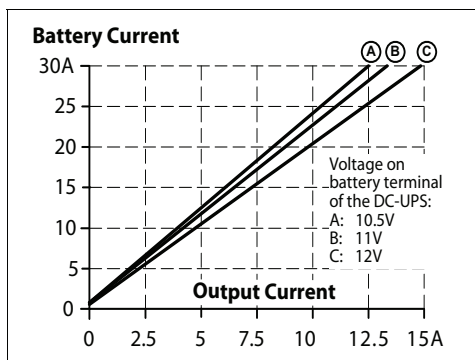
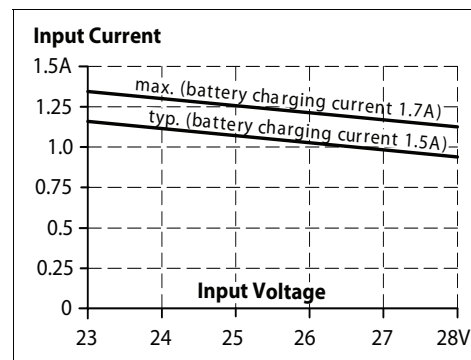

Fig. 8-2 **Required input current vs. input voltage for battery charging (12V not loaded)**



All parameters are specified at an input voltage of 24V, 10A output load, 25°C ambient and after a 5 minutes run-in time unless noted otherwise.

It is assumed that the input power source can deliver a sufficient output current.



## 9. Buffer Time

The buffer time depends on the capacity and performance of the battery as well as the load current. The diagram below shows the typical buffer times of the 24V output with the standard battery modules at 20°C.

Buffer time with battery module 1606-XLSBATASSY1	min.	18'30"	At 5A output current *)
	min.	5'30"	At 10A output current *)
	typ.	20'50"	At 5A output current, see Fig. 9-1 **)
	typ.	6'30"	At 10A output current, see Fig. 9-1 **)
Buffer time with battery module 1606-XLSBATASSY2	min.	96'30"	At 5A output current *)
	min.	37'50"	At 10A output current *)
	typ.	126'	At 5A output current, see Fig. 9-1 **)
	typ.	53'20"	At 10A output current, see Fig. 9-1 **)

\*) Minimum value includes 20% aging of the battery and a cable length of 1.5m with a cross section of 2.5mm<sup>2</sup> between the battery and the DC-UPS and requires a fully charged (min. 24h) battery.

\*\*\*) Typical value includes 10% aging of the battery and a cable length of 0.3m with a cross section of 2.5mm<sup>2</sup> between the battery and the DC-UPS and requires a fully charged (min. 24h) battery.

Fig. 9-1 Buffer time vs. 24V output current with the battery modules 1606-XLSBATASSY1 and 1606-XLSBATASSY2

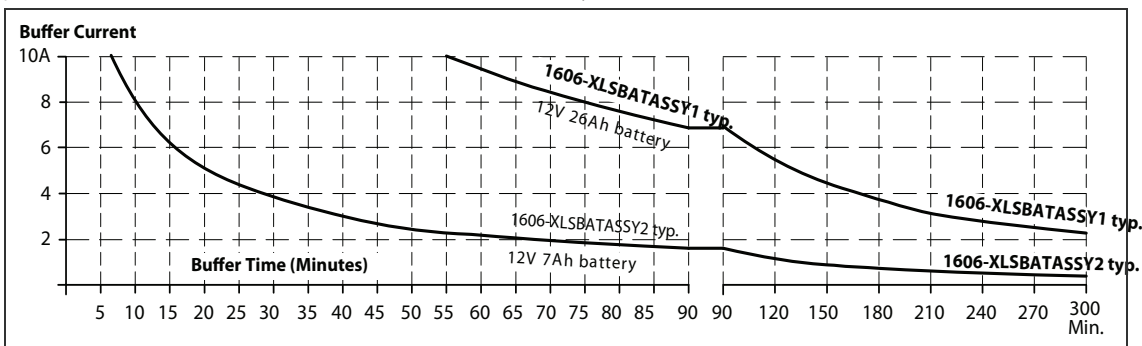

**The buffer time is reduced if the 12V output is loaded.** This can be calculated according to the following example:

**Example:** 24V, 5A and 12V, 4A load

**Step 1: Convert the 12V current to a virtual 22.3V level:**

$$\text{Ratio: } 12\text{V}/22.3\text{V} = 0.54 \quad 12\text{V, } 4\text{A output converted to } 22.3\text{V level: } 0.54 * 4\text{A} = 2.15\text{A}$$

**Step 2: Add the computed current to the actual 24V current:**

$$2.15\text{A} + 5\text{A} = 7.15\text{A}$$

**Step 3: Determine the buffer time by using the standard buffer time curve** (Fig. 9-1):

7.15A load with 1606-XLSBATASSY2: Approx. 12 minutes buffer time.

The battery capacity is usually specified in amp-hours (Ah) for a 20h discharging event. The battery discharge is non-linear (due to the battery chemistry). The higher the discharging current, the lower the appropriate battery capacity. The magnitude of the reduction depends on the discharging current as well as on the type of battery. High current battery types can have up to 50% longer buffer times compared to regular batteries when batteries will be discharged in less than 1 hour. High discharging currents do not necessarily mean high power losses as the appropriate battery capacity is reduced with such currents. When the battery begins to recharge after a discharging

event, the process is completed much faster since only the energy which was taken out of the battery needs to be “refilled”. For this reason, the buffer time cannot be calculated using the Ah capacity value.

The equation “ $I \times t$ ” = capacity in Ah generally leads to incorrect results when the discharging current is higher than C20 (discharging current for 20h). The battery datasheet needs to be studied and a determination of the expected buffer time can be made by following the example below:

**Example how to determine the expected buffer time for other battery types and battery sizes:**

**Step 1** Check the datasheet of the battery which is planned to be used and look for the discharging curve. Sometimes, the individual discharging curves are marked with relative C-factors instead of current values. This can easily be converted. Multiply the C-factor by the nominal battery capacity to obtain the current value. E.g.: 0.6C on a 17Ah battery means 10.2A.

Fig. 9-2 **Typical discharging of a typical 17Ah battery, curve taken from a manufacturer’s datasheet**

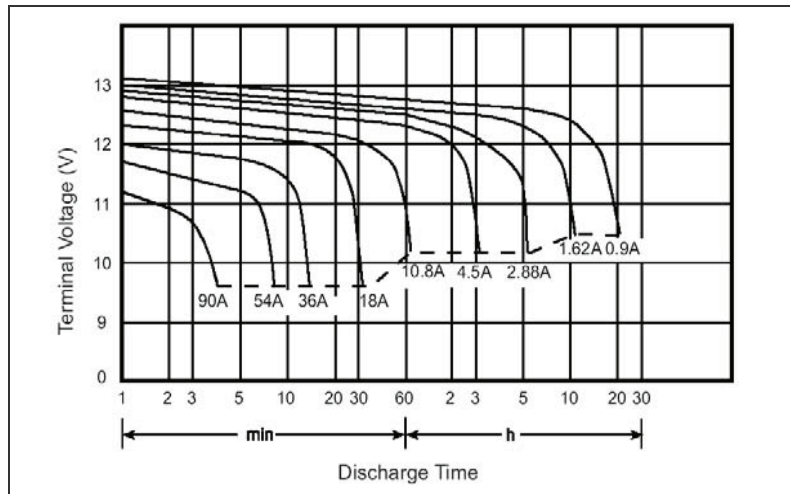

**Step 2** Determine the required battery current. Use Fig. 8-1 “Battery discharging current vs. output current” to get the battery current. Fig. 8-1 requires the average voltage on the battery terminals. Since there is a voltage drop between the battery terminals and the battery input of the DC-UPS, it is recommended to use the curve A or B for output currents > 3A or when using long battery cables. In all other situations, use curve C.

**Step 3** Use the determined current from Step 2 to find the appropriate curve in Fig. 9-2. The buffer time (Discharging Time) can be found where this curve meets the dotted line. This is the point where the DC-UPS stops buffering due to the under-voltage lockout.

**Step 4** Depending on Fig. 9-2, the buffer time needs to be reduced to take into account aging effects or guaranteed values.

Example:

Buffer current is 24V 7.5A and a battery according to Fig. 9-2 is used. The cable between the battery and the DC-UPS is 1m and has a cross-section of 2.5mm<sup>2</sup>. How much is the maximum achievable buffer time?

Answer:

- According to Fig. 8-1, the battery current is 18A. Curve A is used since the battery current is > 3A and the length of the cable is one meter.
- According to Fig. 9-2, a buffer time (Discharging Time) of 30 minutes can be determined. It is recommended to reduce this figure to approximately 24 minutes for a guaranteed value and to cover aging effects.

All parameters are specified at an input voltage of 24V, 10A output load, 25°C ambient and after a 5 minutes run-in time unless noted otherwise.

It is assumed that the input power source can deliver a sufficient output current.

## 10. Efficiency and Power Losses

Efficiency	typ.	97.5%	Normal mode, 24V 10A, 12V 0A, battery fully charged
	typ.	96%	Normal mode, 24V 7.0A, 12V 5A, battery fully charged
Power losses	typ.	3.4W	Normal mode, no load, battery fully charged
	typ.	6W	Normal mode, 24V 10A, 12V 0A, battery fully charged
	typ.	10W	Normal mode, 24V 12.3A, 12V 5A, battery fully charged
	typ.	5.5W	During battery charging, no load.
	typ.	19W	Buffer mode, 24V 10A, 12V 0A
	typ.	23W	Buffer mode, 24V 7.0A, 12V 5A

## 11. Functional Diagram

Fig. 11-1 Functional Diagram

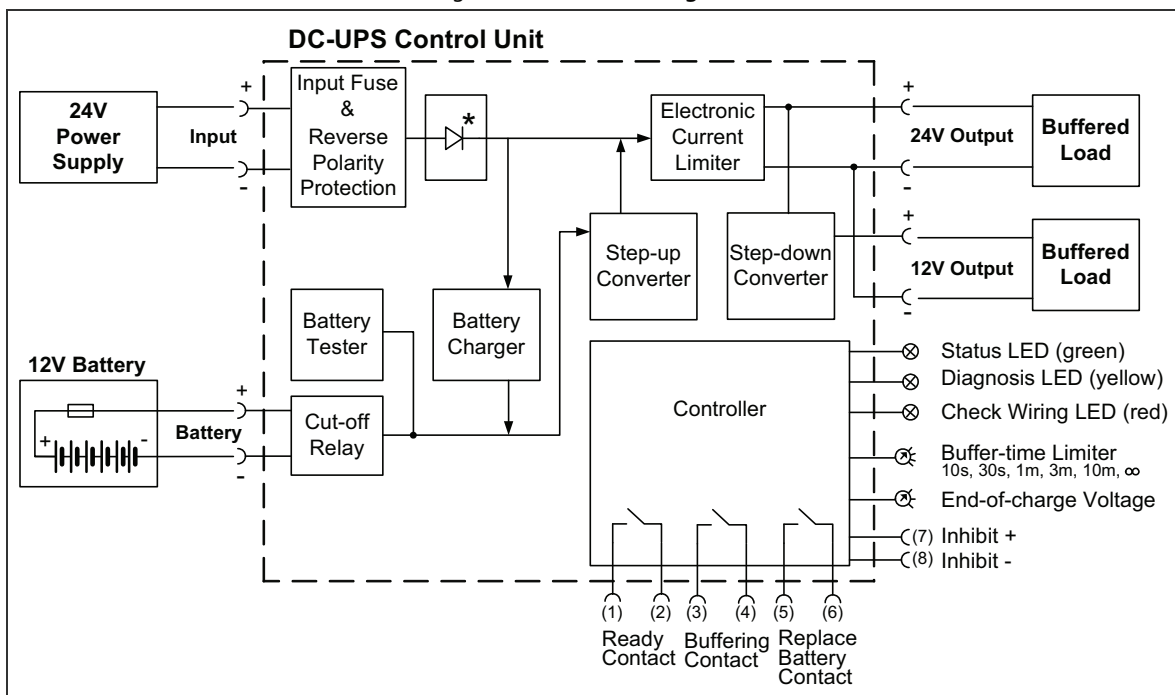

\*) Return current protection: this feature uses a Mosfet instead of a diode in order to minimize the voltage drop and power losses.

## 12. Check Wiring and Battery Quality Tests

---

The DC-UPS is equipped with an automatic “Check Wiring” and “Battery Quality” test.

### “Check Wiring” test:

Under normal circumstances, an incorrect or bad connection from the battery to the DC-UPS or a missing (or blown) battery fuse would not be recognized by the UPS when operating in normal mode. Only when backup is required would the unit be unable to buffer. Therefore, a “check wiring” test is included in the DC-UPS. This connection is tested every 10 seconds by loading the battery and analyzing the response from the battery. If the resistance is too high, or the battery voltage is not in range, the unit displays “Check Wiring” along with the red LED. At the same time the green “Ready” LED will turn off.

### “Battery Quality” or “State of Health” (SoH) test:

The battery has a limited service life and needs to be replaced at fixed intervals defined by the specified service life (acc. to the Eurobat guideline), based on the surrounding temperature and the number of charging/discharging cycles. If the battery is used longer than the specified service life, battery capacity will degrade. Details can be found in section 26.1. The battery quality test cannot identify a gradual loss in capacity. It is however able to detect a battery failure within the specified service life of the battery. Therefore a battery quality test is included in the DC-UPS.

The battery quality test consists of different types of tests:

- During charging:  
If the battery does not reach the ready status (see section 14) within 30 hrs, it is considered to be defective. This could be due to a broken cell inside the battery.
- During operation:  
Once the battery is fully charged, a voltage drop test and a load test are performed alternately every 8 hours. Three of the tests must consecutively produce negative results to indicate a battery problem.

A battery problem is indicated by the yellow LED (replace battery pattern) and the relay contact “Replace Battery.” Please note that it can take up to 50 hours (with the largest size battery) until a battery problem is reported. This should avoid nuisance error messages as any urgent battery problems will be reported by the “Check Wiring” test and create a warning signal. Battery tests require up to 50 hours of uninterrupted operation. Any interruption in the normal operation of the DC-UPS may induce the “Replace Battery” test cycle to start all over.

When “Replace battery” is indicated, we recommend replacing the battery as soon as possible.

## 13. Relay Contacts and Inhibit Input

The DC-UPS is equipped with relay contacts and signal inputs for remote monitoring and control of the unit.

### Relay contacts:

**Ready:** Contact is closed when battery is charged more than 85%, no wiring failure is recognized, input voltage is sufficient and inhibit signal is inactive.

**Buffering:** Contact is closed when unit is buffering.

**Replace Battery:** Contact is closed when the unit is powered from the input and the battery quality test (SoH test) reports a negative result.

Relay contact ratings	max	60Vdc 0.3A, 30Vdc 1A, 30Vac 0.5A resistive load
	min	1 mA at 5Vdc min.
Isolation voltage	max	500Vac, signal port to power port

### Signal input:

**Inhibit:** The inhibit input disables buffering. In normal mode, a static signal is required. In buffer mode, a pulse with a minimum length of 250ms is required to stop buffering. The inhibit is stored and can be reset by cycling the input voltage. See also section 26.1 for application hints.

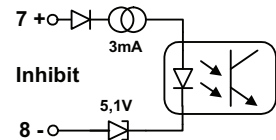

Signal voltage	max.	35Vdc
Signal current	max.	6mA, current limited
Inhibit threshold	min.	6Vdc, buffering is disabled above this threshold level
	max.	10Vdc
Isolation	nom.	500Vac, signal port to power port

All parameters are specified at an input voltage of 24V, 10A output load, 25°C ambient and after a 5 minutes run-in time unless noted otherwise.

It is assumed that the input power source can deliver a sufficient output current.

Rockwell Automation Publication 1606-RM017A-EN-P — February 2014

## 14. Front Side User Elements

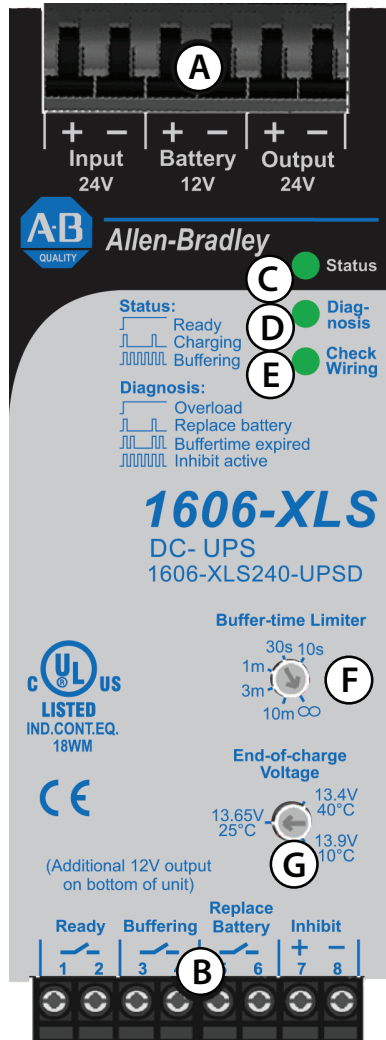

### A Power Port

Quick-connect spring-clamp terminals, connection for input voltage, output voltage and battery. The 12V power port is placed on the bottom.

### B Signal Port

Plug connector with screw terminals, inserted from the bottom. Connections for the Ready, Buffering, Replace Battery relay contacts and for the Inhibit input. See details in section 13.

### C Green Status LED

**Ready:** Battery is charged > 85%, no wiring failure is recognized, input voltage is sufficient and inhibit signal is not active.

**Charging:** Battery is charging and the battery capacity is below 85%.

**Buffering:** Unit is in buffer mode.

Flashing pattern of the green status LED:

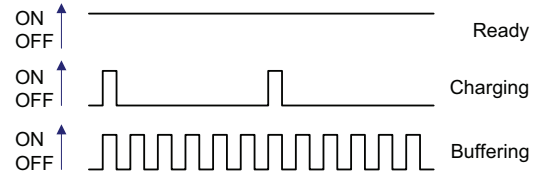

### D Yellow Diagnosis LED

**Overload:** Output has switched off due to long overload in buffer mode or due to high temperatures.

**Replace battery:** Indicates a battery which failed the battery quality test (SoH test). Battery should be replaced soon.

**Buffer-time expired:** Output has switched off due to settings of Buffer-timer Limiter. This signal will be displayed for 15 minutes.

**Inhibit active:** Indicates that buffering is disabled because of an inactive inhibit signal.

Flashing pattern of the yellow diagnosis LED:

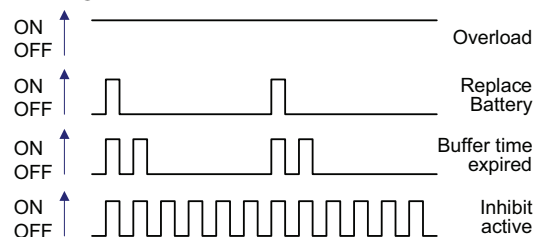

### E Red Check Wiring LED

This LED indicates a failure in the installation (e.g. input voltage excessively low), wiring, battery or battery fuse.

### F Buffer-time Limiter:

User accessible dial which limits the maximum buffer time in a buffer event to save battery energy. When the battery begins to recharge after a discharge event, the process is completed much faster since only the energy which was taken out of the battery needs to be "refilled". The following times can be selected: 10 seconds, 30 seconds, 1 minute, 3 minutes, 10 minutes or infinity (until battery is flat) which allows buffering until the deep discharge protection stops buffering.

### G End-of-charge Voltage Selector:

The end-of-charge-voltage shall be set manually according to the expected temperature in which the battery is located. The dial on the front of the unit allows a continuous adjustment between +10 and +40°C. 10°C will set the end-of-charge-voltage to 13.9V, 25°C → 13.65V and 40°C → 13.4V. If in doubt about the expected temperature, set the unit to 35°C.

All parameters are specified at an input voltage of 24V, 10A output load, 25°C ambient and after a 5 minutes run-in time unless noted otherwise.

It is assumed that the input power source can deliver a sufficient output current.

Rockwell Automation Publication 1606-RM017A-EN-P — February 2014

## 15. Terminals and Wiring

	<b>Power terminals</b> (except 12V)	<b>12V Terminal</b>	<b>Signal terminals</b>
Type	Bi-stable, quick-connect spring-clamp terminals. Shipped in open position.	Lockable plug connector with spring-clamp terminals.	Plug connector with screw terminal. Shipped in open position. To meet GL requirements, unused terminal compartments should be closed.
Solid wire	0.5-6mm <sup>2</sup>	0.1-2.5mm <sup>2</sup>	0.2-1.5mm <sup>2</sup>
Stranded wire	0.5-4mm <sup>2</sup>	0.1-2.5mm <sup>2</sup>	0.2-1.5mm <sup>2</sup>
AWG	20-10AWG	28-12AWG	22-14AWG
Ferrules	Allowed, but not required	Allowed, but not required	Allowed, but not required
Pull-out force	10AWG:80N, 12AWG:60N, 14AWG:50N, 16AWG:40N according to UL486E		Not applicable
Recom. screwdriver	Not required	3,5mm slotted	3,5mm slotted
Tightening torque	Not applicable	Not applicable	0.4Nm, 3.5lb.in
Wire stripping length	10mm / 0.4 in.	8.5mm / 0.34 in.	6mm / 0.24 in.

Fig. 15-1 Spring-clamp terminals, connecting a wire

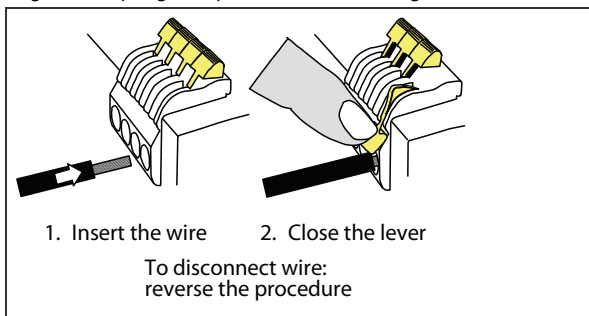

### Instructions:

- Use appropriate copper cables, that are designed for an operating temperature of 60°C
- Follow national installation codes and regulations!
- Ensure that all strands of a stranded wire are properly inserted in the terminal connection!
- Up to two stranded wires with the same cross section are allowed in one connection point.

## 16. Reliability

---

Lifetime expectancy, normal mode	min.	114 000 h	At 10A output current, 40°C
	min.	148 000 h	At 5A output current, 40°C
	min.	380 000 h	At 10A output current, 25°C
MTBF SN 29500, IEC 61709, normal mode		788 000 h	At 10A output current, 40°C
MTBF MIL HDBK 217F, normal mode		343 000 h	At 10A output current , 40°C, ground benign GB40

The **Lifetime expectancy** shown in the table indicates the operating hours (service life) and is determined by the lifetime expectancy of the built-in electrolytic capacitors. Lifetime expectancy is specified in operational hours. Lifetime expectancy is calculated according to the capacitor’s manufacturer specification. The prediction model allows a calculation of up to 15 years from date of shipment.

**MTBF** stands for **Mean Time Between Failures** which is calculated according to statistical device failures and indicates reliability of a device. It is the statistical representation of the likelihood of failure of a unit and does not necessarily represent the life of a product.

All parameters are specified at an input voltage of 24V, 10A output load, 25°C ambient and after a 5 minutes run-in time unless noted otherwise.

It is assumed that the input power source can deliver a sufficient output current.



## 17. EMC

The unit is suitable for applications in industrial environmental as well as in residential, commercial and light industry environment without any restrictions. The CE Mark is in conformance with EMC directive 89/336/EC and 93/68/EC & 2004/108/EC and the low-voltage directive (LVD) 73/23/EC, 93/68/EC, 2006/95/EC.

A detailed EMC Report is available on request.

<b>EMC Immunity</b>	EN 61000-6-1, EN 61000-6-2	Generic standards		
Electrostatic discharge	EN 61000-4-2	Contact discharge	8kV	Criterion A*)
		Air discharge	15kV	Criterion A *)
Electromagnetic RF field	EN 61000-4-3	80MHz-1GHz	10V/m	Criterion A
Fast transients (Burst)	EN 61000-4-4	Out- and input lines	2kV	Criterion A
		Signal lines **)	2kV	Criterion A
Surge voltage	EN 61000-4-5	Input + / - → housing	500V	Criterion A
		24V Output + → - housing	500V	Criterion A
		12V Output + / - → housing	500V	Criterion A
		24V Output + → -	500V	Criterion A
		Input + → -	500V	Criterion A
Conducted disturbance	EN 61000-4-6	0,15-80MHz	10V	Criterion A

\*) DIN rail grounded

\*\*) Tested with coupling clamp

<b>EMC Emission</b>	EN 61000-6-3, EN 61000-6-4	Generic standards	
Conducted emission	EN 55022	Input lines	Class B *)
	EN 55022	24V Output lines	Class B *)
	EN 55022	12V Output lines	Class A *)
Radiated emission	EN 55011, EN 55022		Class B

This device complies with FCC Part 15 rules.

Operation is subjected to the following two conditions: (1) this device may not cause harmful interference, and (2) this device must accept any interference received, including interference that may cause undesired operation.

\*) Informative measurement with voltage probe

### Switching Frequencies

The DC-UPS has four converters with four different switching frequencies included.

Switching frequency of boost converter	100kHz	Constant frequency
Switching frequency of electronic output current limitation	78kHz	Constant frequency
Switching frequency of battery charger	19.5kHz	Constant frequency
Switching frequency of step-down converter 12V output	40-55kHz	Depending on 12V output load

## 18. Environment

Operational temperature	-25°C to +70°C (-13°F to 158°F)	For the DC-UPS control unit. Keep battery in a cooler environment!
Derating	6W/°C	at +50°C to +70°C (122°F to 158°F), normal mode see Fig. 18-1, buffer mode see Fig. 18-2
Storage temperature	-40 to +85°C (-40°F to 185°F)	Storage and transportation, except battery
Humidity	5 to 95% r.H.	IEC 60068-2-30 Do not energize in the presence of condensation.
Vibration, sinusoidal	2-17.8Hz: ±1.6mm; 17.8-500Hz: 2g	IEC 60068-2-6
Shock	30g 6ms, 20g 11ms	IEC 60068-2-27
Altitude	0 to 6000m	Approvals apply only up to 2000m
Over-voltage category	III	EN 50178
	II	EN 50178 above 2000m altitude
Degree of pollution	2	EN 50178, not conductive

Fig. 18-1 **Output current vs. ambient temperature in normal mode**

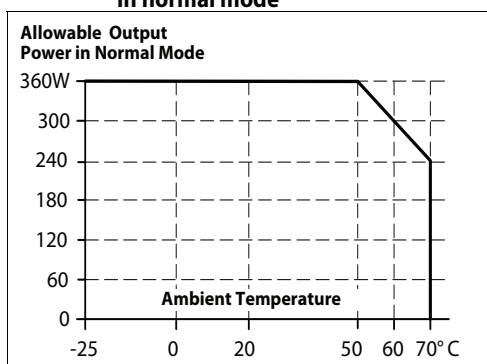
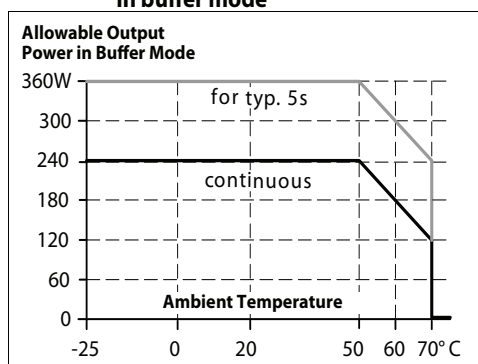

Fig. 18-2 **Output current vs. ambient temperature in buffer mode**



The ambient temperature is defined 2cm below the unit.

## 19. Protection Features

Output protection	Electronically protected against overload, no-load and short-circuits	
Output over-voltage protection	typ. 32Vdc max. 35Vdc	24V Output In case of an internal defect, a redundant circuitry limits the maximum output voltage. The output automatically shuts down and makes restart attempts.
	max. 16V	12V Output: The unit is protected with a melting fuse. In case the fuse has triggered, return unit to factory.
Degree of protection	IP20	EN/IEC 60529
Penetration protection	> 3.5mm	E.g. screws, small parts
Reverse battery polarity protection	yes	Max. -35Vdc;
Wrong battery voltage protection	yes	Max. +35Vdc (e.g. 24V battery instead of 12V battery)
Battery deep discharge protection	yes	The limit depends on the battery current.
Over temperature protection	yes	Output shut-down with automatic restart
Input over-voltage protection	yes	Max. 35Vdc, no harm to or defect of the unit
Internal input fuse	25A, blade type	No user accessible part, no service part

All parameters are specified at an input voltage of 24V, 10A output load, 25°C ambient and after a 5 minutes run-in time unless noted otherwise.







It is assumed that the input power source can deliver a sufficient output current.

Rockwell Automation Publication 1606-RM017A-EN-P — February 2014

## 20. Safety

Output voltage	SELV PELV Max. allowed voltage between any input, output or signal pin and ground: 60Vdc or 42.4Vac	IEC/EN 60950-1 EN 60204-1, EN 50178, IEC 60364-4-41
Class of protection	III	PE (Protective Earth) connection is not required
Isolation resistance	> 5MΩ	Power port to housing, 500Vdc
Dielectric strength	500Vac	Power port to signal port
	500Vac	Power port / signal port to housing
Touch current (leakage current)	The leakage current which is produced by the DC-UPS itself depends on the input voltage ripple and need to be investigated in the final application. For a smooth DC input voltage, the produced leakage current is less than 100 μA.	

## 21. Certifications

UL 508		LISTED E56639 listed for use in the U.S.A. (UL 508) and Canada (C22.2 No. 14-95) Industrial Control Equipment
UL 60950-1		RECOGNIZED E168663 recognized for use in the U.S.A. (UL 60950-1) and Canada (C22.2 No. 60950) Information Technology Equipment, Level 3
ISA 12.12.01, CSA C22.2 No. 213		RECOGNIZED UNDER FILE NUMBER E244404 for use in the U.S.A. (ISA 12.12.01) and Canada (C22.2 No. 213) Hazardous Location Class I Div. 2 - Groups A, B, C, D
EN 60950-1, EN 61204-3		Complies with CE EMC and CE Low Voltage Directives
Marine RINA		RINA (Registro Italiano Navale) certified. See below for link to the Certificate.
GOST R		GOST R certification is applicable for products intended for sale and use withing Russia. See below for link to Certificate.
C-TICK		C-tick compliance is for products intended for sale and use within the Australian market. See below for link to the C-tick Declarations of Conformity.

Product certification information (including Certificates and declarations of Conformity) can be found at [www.ab.com/certification](http://www.ab.com/certification).

## 22. Environmental Compliance

The unit does not release any silicone and is suitable for use in paint shops.

The unit conforms to the RoHS directive 2002/96/EC.

Electrolytic capacitors included in this unit do not use electrolytes such as Quaternary Ammonium Salt Systems.

Plastic housings and other molded plastic materials are free of halogens.

The materials used in our production process do not include the following toxic chemicals: Polychlorinated Biphenyl (PCB), Pentachlorophenol (PCP), Polychlorinated naphthalene (PCN), Polybrominated Biphenyl (PBB), Polybrominated Biphenyl Oxide (PBO), Polybrominated Diphenyl Ether (PBDE), Polychlorinated Diphenyl Ether (PCDE), Polybrominated Diphenyl Oxide (PBDO), Cadmium, Asbestos, Mercury, Silica

## 23. Physical Dimensions and Weight

Width	49mm / 1.93"	
Height	124mm / 4.88"	Plus height of signal and 12V output connector plug (see Fig. 24-1)
Depth	117mm / 4.61"	Plus depth of DIN rail
Weight	650g / 1.43lb	
DIN Rail	Use 35mm DIN rails according to EN 60715 or EN 50022 with a height of 7.5 or 15mm. The DIN rail height must be added to the depth (117mm) to calculate the total required installation depth.	

Fig. 23-1 Side view

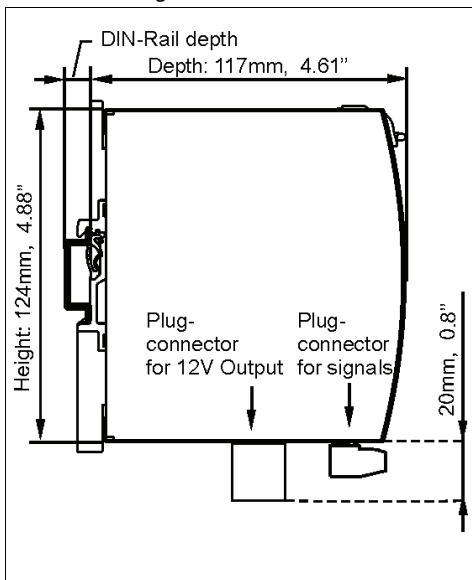
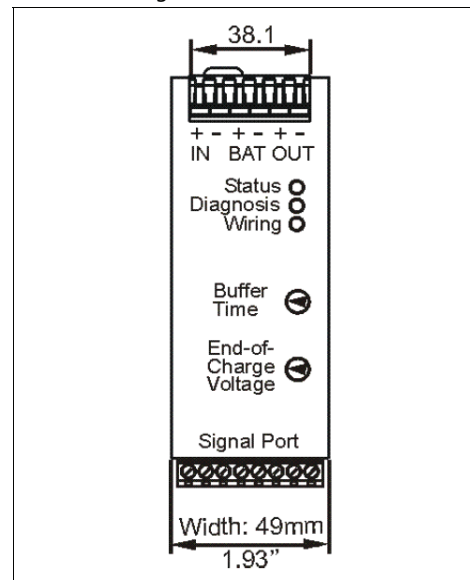

Fig. 23-2 Front view



All parameters are specified at an input voltage of 24V, 10A output load, 25°C ambient and after a 5 minutes run-in time unless noted otherwise.

It is assumed that the input power source can deliver a sufficient output current.

Rockwell Automation Publication 1606-RM017A-EN-P — February 2014

## 24. Installation Notes

### Mounting:

The power terminal must be located on top of the unit. An appropriate electrical and fire end-product enclosure should be considered in the end-use application.

**Cooling:** Convection cooled, no forced air cooling required. Do not obstruct air flow!

**Installation clearances:** 40mm on top, 20mm on the bottom, 5mm on the left and right side are recommended when loaded permanently with full power. In case the adjacent device is a heat source, a clearance of 15mm is recommended.

### Risk of electrical shock, fire, personal injury or death!

Turn power off and disconnect battery fuse before working on the DC-UPS. Protect against inadvertent re-powering. Make sure the wiring is correct by following all local and national codes. Do not open, modify or repair the unit.

Use caution to prevent any foreign object from entering the housing.

Do not use in wet locations or in areas where moisture and/or condensation are likely to be present.

### Service parts:

The unit does not contain any service parts. The tripping of an internal fuse is caused by an internal fault. Should damage or malfunction occur during operation, immediately turn power off and return unit to the factory for inspection!

### Wiring and installation instructions:

- (1) Connect the power supply to the input terminals of the DC-UPS.
- (2) Connect the battery to the battery terminals of the DC-UPS. It is recommended to install the battery outside the cabinet or in a place where the battery will not be heated up by adjacent equipment. Do not install the battery in airtight housings or cabinets. The battery should be installed according to EN50272-2, which includes sufficient ventilation. Batteries store energy and need to be protected against energy hazards. Use a 30A battery fuse type ATO® 257 030 (Littelfuse) or similar in the battery path. The battery fuse protects the wires between the battery and the DC-UPS. It also allows the disconnection of the battery from the DC-UPS which is recommended when working on the battery or DC-UPS. Disconnect battery fuse before connecting the battery.  
Please note: Excessively short or long wires between the DC-UPS and the battery may shorten the buffer time or result in a malfunction of the DC-UPS. Do not use wires smaller than  $2.5\text{mm}^2$  (or 12AWG) and no longer than  $2 \times 1.5\text{m}$  (cord length 1.5m). Avoid voltage drops on this connection.
- (3) Connect the buffered load to the output terminals of the DC-UPS. The 24V output is placed on top of the unit. The 12V output is placed on bottom of the unit behind the signal plug. The output is decoupled from the input allowing load circuits to be easily split into buffered and non buffered sections. Noncritical 24V loads can be connected directly to the power supply and will not be buffered. The energy of the battery can then be used in the circuits which require buffering.
- (4) Install the battery fuse upon completion of the wiring.

Fig. 24-1 Typical wiring diagram

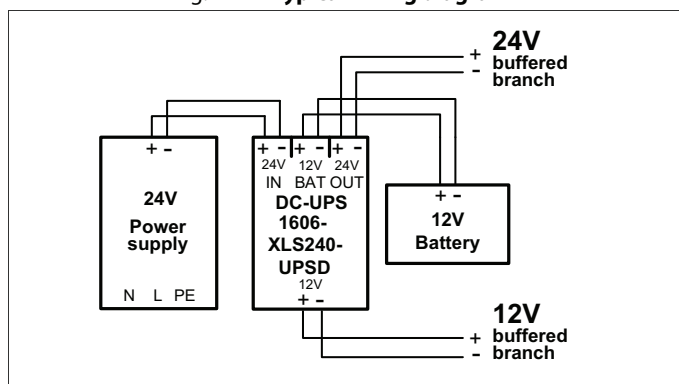

All parameters are specified at an input voltage of 24V, 10A output load, 25°C ambient and after a 5 minutes run-in time unless noted otherwise.

It is assumed that the input power source can deliver a sufficient output current.

Rockwell Automation Publication 1606-RM017A-EN-P — February 2014

## 25. Accessories

### Battery Modules

Two pre-assembled battery modules with a single 12V battery are available for different buffer times. As an option, the mounting brackets are also available without batteries. This option offers more flexibility in selecting an appropriate battery, which can also save on shipping expenses. See individual datasheets for detailed information.

	<b>1606-XLSBATASSY1</b>	<b>1606-XLSBATASSY2</b>	
Battery type	Standard version 12V, 7Ah	High current version 12V, 26Ah	VRLA lead-acid maintenance free battery
Service life	3 to 5 years	10 to 12 years	According to EUROBAT guideline
Dimensions	155x124x112mm	214x179x158mm	Width x height x depth
Weight	3.2kg	9.9kg	
DIN rail mountable	yes	no	
Order number	1606-XLSBATASSY1	1606-XLSBATASSY2	Battery module
	1606-XLSBATBR1	1606-XLSBATBR2	Mounting bracket without battery
	1606-XLSBAT1	1606-XLSBAT2	Replacement battery only

Fig. 25-1 **1606-XLSBATASSY1**



Fig. 25-2 **1606-XLSBATASSY2**



### 1606-XLB Wall / Panel Mounting Bracket

This bracket is used to mount the DC-UPS units onto a flat surface without using a DIN rail. The two aluminium brackets and the black plastic slider of the DC-UPS must be removed to allow the installation of the two surface brackets.

Fig. 25-3 **1606-XLB Wall / Panel Mounting Bracket**

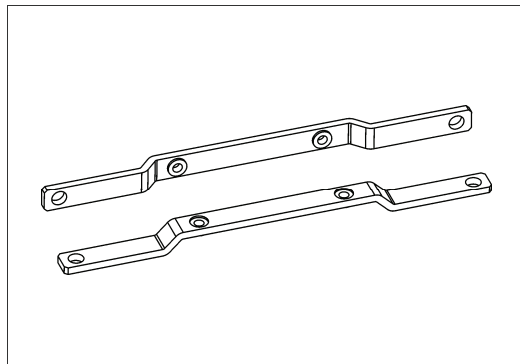
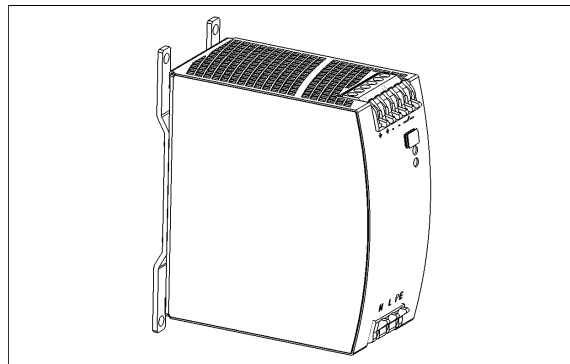

Fig. 25-4 **Assembled Wall / Panel Mounting Bracket**



All parameters are specified at an input voltage of 24V, 10A output load, 25°C ambient and after a 5 minutes run-in time unless noted otherwise.

It is assumed that the input power source can deliver a sufficient output current.

Rockwell Automation Publication 1606-RM017A-EN-P — February 2014

## 26. Application Notes

### 26.1. Battery Replacement Intervals

Batteries have a limited life time. They degrade slowly beginning from the production and need to be replaced periodically. The design life figures can be found in the individual datasheets of the batteries and are usually specified according to the Eurobat guideline or according to specifications from the manufacturer.

The design life is the estimated life based on laboratory condition, and is quoted at 20°C using the manufacturer's recommended float voltage condition. According to the Eurobat guidelines, design lives have been structured into the following different groups:

- 3 - 5 years: This group of batteries is very popular in standby applications and in small emergency equipment. This represents a 4 years design life with a production tolerance of  $\pm 1$  year.
- 6 - 9 years: This group of batteries is usually used when an improved life is required. This represents a 7.5 years design life with a production tolerance of  $\pm 1.5$  years.
- 10 - 12 years: This group of batteries is used in applications that require longest life and highest safety levels. This represents a 11 years design life with a production tolerance of  $\pm$  one year.

A battery failure within the specified design life of the battery usually results in a complete loss of the battery function (broken cell, faulty connection, ...) and will be detected and reported by the periodical battery tests which are included in the 1606-XLS240-UPSD DC-UPS control unit.

If the operational parameters differ from those which are specified for the design life, earlier replacement of the battery might be necessary. The "real life" is also called service life and is defined as the point at which the cell's actual capacity has reached 80% of its nominal capacity. At the end of the service life, capacity degrades much faster; further use of the battery is therefore not recommended.

#### Temperature effect:

The temperature has the most impact on service life. The hotter the temperature, the sooner the wear-out phase of the battery begins. The wear-out results in a degradation of battery capacity. See Fig. 26-1 for details.

#### Effect of discharging cycles

The number as well as the depth of discharging cycles is limited. A replacement of the battery might be necessary earlier than the calculated service life if the battery exceeds the numbers and values of Fig. 26-2.

#### Other effects which shortens the service life

- Overcharging and deep discharging shortens the service life and should be avoided. Thanks to the single battery concept of the 1606-XLS240-UPSD, the end-of-charge-voltage can be set very precisely to the required value and thereby avoiding unnecessary aging effects.
- Charge retention is important to ensure the longest battery life. Stored batteries that are not fully charged age faster than charged batteries. Batteries which are not in use should be recharged at least once a year.
- Excessive float charge ripple across the battery has an effect of reducing life and performance. The 1606-XLS240-UPSD does not produce such a ripple voltage. This effect can be ignored when the battery is charged via the 1606-XLS240-UPSD.

#### Guidelines for a long battery service life

- Place the battery in a cool location: E.g. near the bottom of the control cabinet.
- Do not place the battery near heat generating devices.
- Do not store discharged batteries.
- Do not discharge the battery more than necessary. Set buffer time limiter to the required buffer time.
- When choosing the battery capacity, always try to get the capacity immediately higher than absolutely required. The depth of discharge reduces the service life of the battery and limits the number of cycles. See Fig. 26-2.

**Example for calculating the service life and the required replacement cycle:**

Parameters for the example:

- A 7Ah battery with a design life of 3-5 years is used (e.g. Yuasa battery from the 1606-XLSBATASSY1 battery module).
- The average ambient temperature is 30°C
- One buffer event consumes approx. 25% of the achievable buffer time.
- One buffer event per day

Calculation:

Ambient temperature influence:

According to Fig. 26-1 curve A, a 2 years service life can be expected for an ambient temperature of 30°C.

Number of discharging cycles: 2 years \* 365 cycles = 730cycles in 2 years.

According to Fig. 26-2, curve C has to be used (only 25% of battery capacity is required). 730 cycles have only a negligible influence in battery degradation and can be ignored.

Result:

The battery will need to be replaced after 2 years.

Please note that battery degradation begins from the production date (check date code on the battery) which may shorten the replacement intervals.

Fig. 26-1 **Service life versus ambient temperature, typ. \*)**

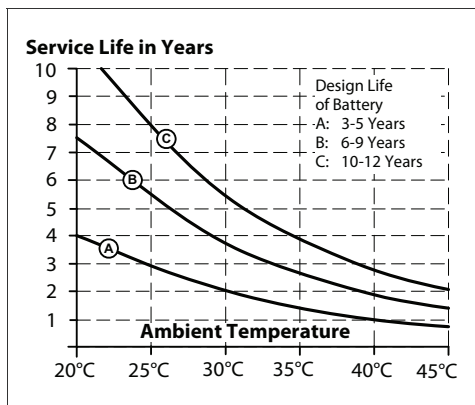
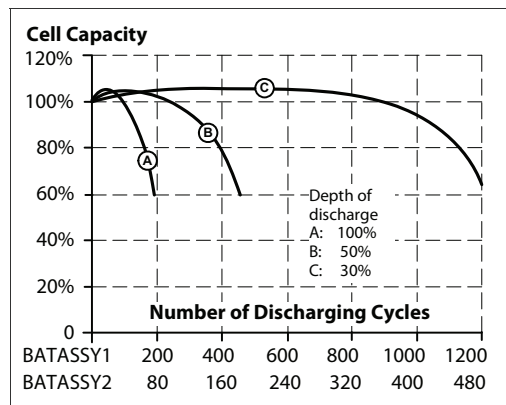

Fig. 26-2 **Cell capacity degradation vs. discharging cycles \*)**



\*) datasheet figures from battery manufacturer

**26.2. Parallel and Serial Use**

Do not use the DC-UPS in parallel to increase the output power. However, two units of the DC-UPS can be paralleled for 1+1 redundancy to gain a higher system reliability.

Do not use batteries in parallel, since the battery quality test might generate an error message.

Do not connect two or more units in series for higher output voltages.

Do not connect two or more units in a row to achieve longer hold-up times.

All parameters are specified at an input voltage of 24V, 10A output load, 25°C ambient and after a 5 minutes run-in time unless noted otherwise.

It is assumed that the input power source can deliver a sufficient output current.



## 26.3. Using the Inhibit Input

The inhibit input disables buffering. In normal mode, a static signal is required. In buffer mode, a pulse with a minimum length of 250ms is required to stop buffering. The inhibit is stored and can be reset by cycling the input voltage.

For service purposes, the inhibit input can also be used to connect a service switch. Therefore, the inhibit signal can be supplied from the output of the DC-UPS.

Fig. 26-3 Wiring example for inhibit input

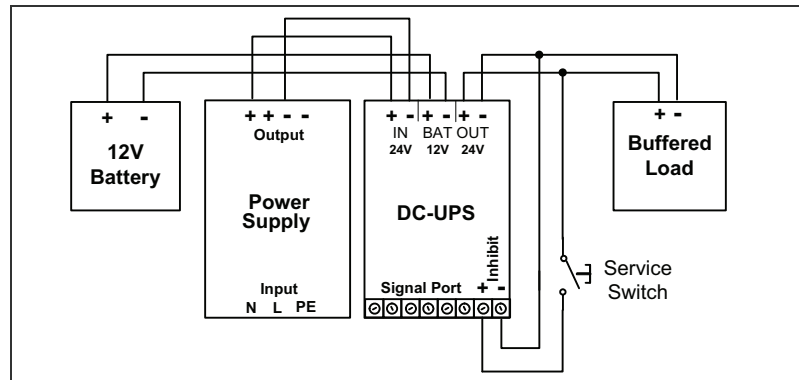

## 26.4. Troubleshooting

The LEDs on the front of the unit and relay contacts indicate about the actual or elapsed status of the DC-UPS. Please see also section 14.

The following guidelines provide instructions for fixing the most common failures and problems. Always start with the most likely and easiest-to-check condition. Some of the suggestions may require special safety precautions. See notes in section 25 first.

### “Check wiring” LED is on

Check correct wiring between the battery and the DC-UPS.  
Check battery fuse. Is the battery fuse inserted or blown?  
Check battery voltage (must be typically between 7.4V and 15.1V).  
Check input voltage (must be typically between 22.8V and 30V).  
Check battery polarity.

### DC-UPS did not buffer

Inhibit input was set.  
Battery did not have enough time to be charged and is still below the deep discharge protection limit.

### DC-UPS stopped buffering

Deep discharge protection stopped buffering → use a larger battery, or allow sufficient time for charging the battery.  
Output was overloaded or short circuit → reduce load.

### Output has shut down

Cycle the input power to reset the DC-UPS.  
Let DC-UPS cool down, over temperature protection might have triggered.

### DC-UPS constantly switches between normal mode and buffer mode

The supplying source on the input is too small and cannot deliver sufficient current.  
→ Use a larger power supply or reduce the output load.

All parameters are specified at an input voltage of 24V, 10A output load, 25°C ambient and after a 5 minutes run-in time unless noted otherwise.  
It is assumed that the input power source can deliver a sufficient output current.



## Rockwell Automation Support

Rockwell Automation provides technical information on the Web to assist you in using its products. At <http://www.rockwellautomation.com/support>, you can find technical manuals, technical and application notes, sample code and links to software service packs, and a MySupport feature that you can customize to make the best use of these tools. You can also visit our Knowledgebase at <http://www.rockwellautomation.com/knowledgebase> for FAQs, technical information, support chat and forums, software updates, and to sign up for product notification updates.

For an additional level of technical phone support for installation, configuration, and troubleshooting, we offer TechConnect<sup>SM</sup> support programs. For more information, contact your local distributor or Rockwell Automation representative, or visit <http://www.rockwellautomation.com/support/>.

## Installation Assistance

If you experience a problem within the first 24 hours of installation, review the information that is contained in this manual. You can contact Customer Support for initial help in getting your product up and running.

United States or Canada	1.440.646.3434
Outside United States or Canada	Use the <a href="http://www.rockwellautomation.com/rockwellautomation/support/overview.page">Worldwide Locator</a> at <a href="http://www.rockwellautomation.com/rockwellautomation/support/overview.page">http://www.rockwellautomation.com/rockwellautomation/support/overview.page</a> , or contact your local Rockwell Automation representative.

## New Product Satisfaction Return

Rockwell Automation tests all of its products to help ensure that they are fully operational when shipped from the manufacturing facility. However, if your product is not functioning and needs to be returned, follow these procedures.

United States	Contact your distributor. You must provide a Customer Support case number (call the phone number above to obtain one) to your distributor to complete the return process.
Outside United States	Please contact your local Rockwell Automation representative for the return procedure.

## Documentation Feedback

Your comments will help us serve your documentation needs better. If you have any suggestions on how to improve this document, complete this form, publication [RA-DU002](#), available at [http://literature.rockwellautomation.com/idc/groups/literature/documents/du/ra-du002\\_-en-e.pdf](http://literature.rockwellautomation.com/idc/groups/literature/documents/du/ra-du002_-en-e.pdf).

**[www.rockwellautomation.com](http://www.rockwellautomation.com)**

### Power, Control and Information Solutions Headquarters

Americas: Rockwell Automation, 1201 South Second Street, Milwaukee, WI 53204-2496 USA, Tel: (1) 414.382.2000, Fax: (1) 414.382.4444  
Europe/Middle East/Africa: Rockwell Automation NV, Pegasus Park, De Kleetlaan 12a, 1831 Diegem, Belgium, Tel: (32) 2 663 0600, Fax: (32) 2 663 0640  
Asia Pacific: Rockwell Automation, Level 14, Core F, Cyberport 3, 100 Cyberport Road, Hong Kong, Tel: (852) 2887 4788, Fax: (852) 2508 1846