

AMD 120 DIP BLOCKED CHUTE / LEVEL SWITCH



A & M Controls Blocked Chute/Level Switch Designed and Manufactured by A & M Controls

Blocked Chute/Level Switch DIP IP65

(Aus Ex 3677 Certificate expired)

Suitable for use in I.S. circuits as a simple device

For use on free flowing materials at atmospheric pressure.

Grain - Flour - Pellets - Cement - Ash - Crushed Rock - Sand - Coal - Sewerage Sludge

A very rugged and reliable switch which will operate on most applications in the Grain, Quarry Mining, Power and Materials Handling Industries as a blocked chute switch or level switch. Other advantages are that it will operate on any control voltage and is a simple on/off, 2 wire system which does not require a power supply, motor circuit or extra fittings.

Company Message

A&M Controls was established in 1980 to design and manufacture blocked chute and level switches for use in a number of industries requiring a simple, reliable and inexpensive switch.

After many years of experience in the Electrical and Instrument field associated with the Grain, Stockfeed, Mining and Power Industries we have achieved that aim and are still improving our products

to maintain the satisfaction of our extensive customer base.

Our standard of quality control is jealously guarded and we appreciate customer feedback so that we can customize their needs.

Specification of the Blocked Chute Switch

AMD 120 DIP BLOCKED CHUTE / LEVEL SWITCH

For use on free flowing materials at atmospheric pressure. The AMD 120 DIP can eliminate spillage and expensive clean-ups in cases of Bin overflow or conveying blockages. Dependability and low cost are synonymous with the AMD 120 DIP.

For best results and sensitivity, connect with a 20mm conduit to allow the dissipation of displaced air in the housing caused by the movement of the diaphragm.

Specification:

AMD 120 DIP Blocked Chute switch

Suitable for use in I.S. circuits as a simple device.

Aluminium Casting
Faceflange is 304 Stainless Steel
Fully Gasketed - it is both weather and dust proof
Hard wearing diaphragm
Temperature to 110 Deg. C.
Two wire circuit N/O or N/C SPDT.
Voltage 12V to 240V. Rated 2 Amps
Sensitivity Adjustment.
Electrical Conduit Entry - 20mm.
Mounting is 6 x 6mm on 154 PCD
Bin cutout is 110 mm.
Shipping weight is 1.25 kgs.

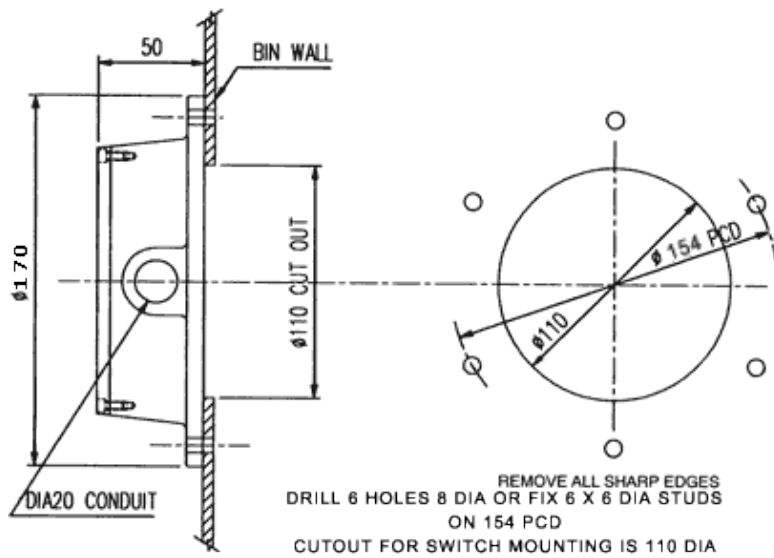

AMD-WMF Mounting Flange

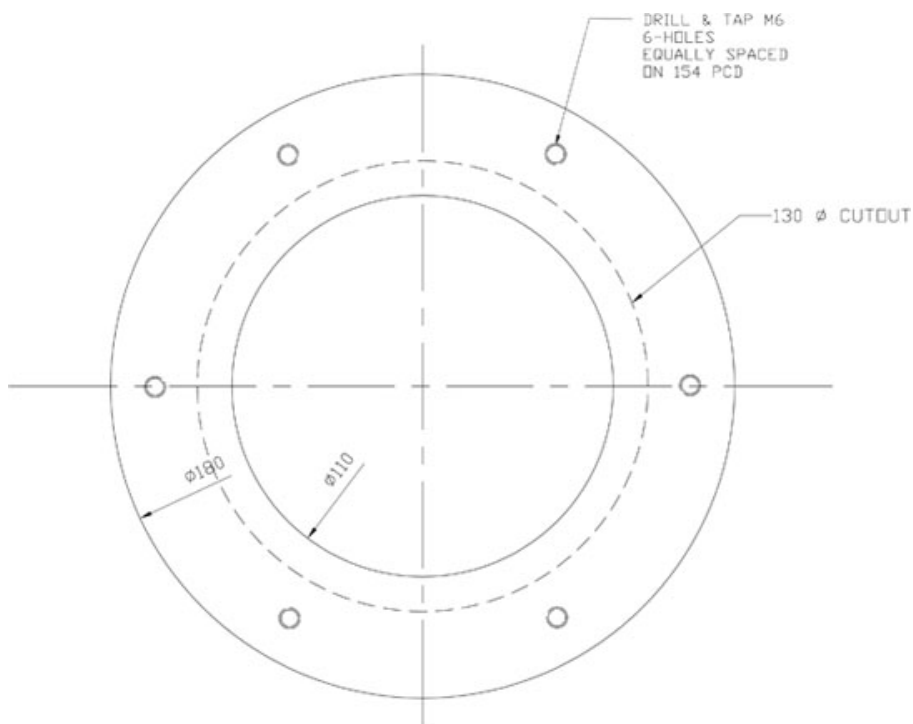

MAT,L 4mm PLATE MS ZINC PLATED
 SUPPLIED WITH 6 OFF M6 X 30 SET SCREWS ZINC PLATED

INSTALLATION

CUT HOLE \varnothing 130 IN CHUTE AND WELD WMF FLANGE
 IN PLACE THEN MOUNT AMD 120 SWITCH

AMD –NP Hopper Level Switch.



Applications to detect the level of fly ash and flue gas particles collected in Electrostatic Precipitators and Fabric Filter Dust Collection Plants operating at negative pressure and temperatures up to 210 Degrees C.

Specification:

Enclosure is certified IP65.

End connection to 80mm (3 inch) ANSI 150 flange, for bolting to flanged spigot welded on dust hopper.

Flange spigot on hopper to be at least 30 Deg above horizontal with the 30mm (1.25 inch) sensing tube facing in a downward direction into the product. Switch housing can be mounted at any angle it can also be mounted directly to a 1.25 inches BSP pipe thread.

Conduit / Cable entry is 20mm.

Electrical connections are, common, N/O and N/C, SPDT switch.

Two or three wire circuit. (At any control voltage)

No power supply or ancillary circuits required.

Hopper negative pressure -0.5 Kpa to -8 Kpa or better.

Through gas temperatures to 210 Deg. C.

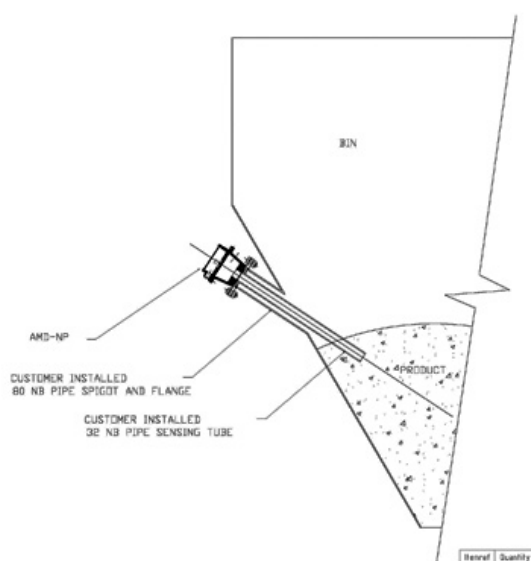

Contact Us

A & M Controls can be contacted at

email:

contact@amcontrols.com

Within Australia:

Phone (03) 5985 1924

Fax (03) 5985 1924

Mobile: 0407779094

International:

Phone 613 5985 1924

Fax 613 5985 1924