



# LP

## T8 SERIES

The Slimline T8 is a multi-purpose luminaire suitable for domestic and most commercial and industrial applications, providing optimum lighting levels at the lowest cost. Designed for surface mounting, conduit or chain suspension, this is a truly versatile and functional design. The LP series utilises the T8 26 mm high efficiency fluorescent tube, combining form and function that is not only visually pleasing but also offers easy installation, maintenance and tube replacement.

### FEATURES

- » Durable slimline steel construction, with both single and twin lamp batters having a base of only 54mm
- » Simple 90° turn twist toggles allow easy access to the gear tray without the need for tools
- » Electronic control gear as standard
- » Large terminal blocks for fast/easy cable connection
- » Chassis and accessory metal surfaces treated & degreased, finished in a white polyester-epoxy powder-coat and baked for unprecedented protection and the highest quality finish
- » Replaceable polycarbonate lamp holders securely held in UV stabilised, non-discolouring, high impact end cap assemblies
- » Diffuser, wire guarded & reflector kits available as add on attachments to the bare tube model
- » Available in wiring configurations to suit local requirement
- » 12 month warranty from date of purchase

### APPLICATIONS

- » Green Star / BCA approved buildings
- » Motel / hotels, hospitals
- » Shopping centres, art galleries
- » Offices, commercial interiors, showrooms
- » Boardrooms, lecture theatres, schools

### OPTIONS

- » Reflector kit
- » Diffuser kit
- » Emergency module
- » Smart intelligent ballast
- » Dimming gear
- » Fused terminal block

### SPECIFICATIONS

Model	Power	Length	Model	Power	Length
LP118EL	1 x 18 W	609 mm	LP218EL	2 x 18 W	609 mm
LP130EL	1 x 30 W	913 mm	LP230EL	2 x 30 W	913 mm
LP136EL	1 x 36 W	1218 mm	LP236EL	2 x 36 W	1218 mm
LP158EL	1 x 58 W	1519 mm	LP258EL	2 x 58 W	1519 mm

Slimline series batters are available in a number of configurations Change "LP" above to:

<b>LPS</b>	Square diffused	<b>LPCR</b>	Curved reflector
<b>LPW</b>	Wire guard	<b>LPCA</b>	Curved angled reflector
<b>LPR</b>	Reflector	<b>LPRW</b>	Reflector / wire guard
<b>LPMR</b>	Mirror reflector	<b>LPWA</b>	Angled reflector / wire guard
<b>LPA</b>	Angled reflector		
<b>LPMA</b>	Mirror angled reflector		



**LIGHTING DATA**

LP236EL

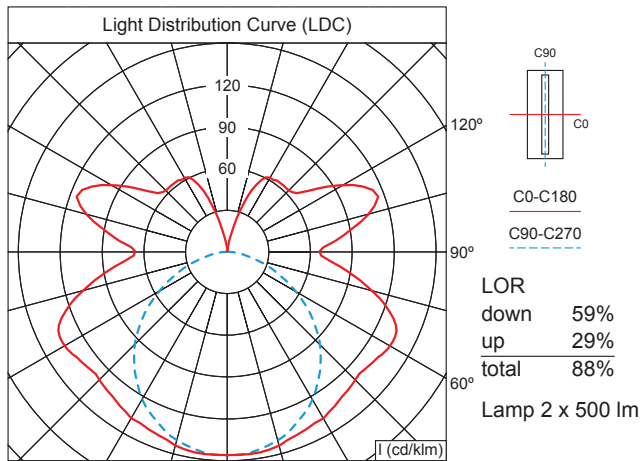

Utilisation Table (TM5)				LP236EL.IES							
Reflectances			Room Index								
C	W	F	0.75	1.0	1.25	1.5	2.0	2.5	3.0	4.0	5.0
70	50	20	40	47	53	57	63	68	71	75	78
70	30	20	33	40	46	50	57	62	66	71	74
70	10	20	28	34	41	45	52	57	61	67	71
50	50	20	36	42	47	51	56	60	62	66	69
50	30	20	30	36	41	45	51	55	59	63	66
50	10	20	26	31	37	41	47	52	55	60	63
30	50	20	32	37	41	45	59	53	55	58	60
30	30	20	27	32	37	40	45	49	52	56	58
30	10	20	24	28	33	37	42	46	49	53	56
0	0	0	19	23	27	30	34	37	40	43	45
BZ-class			N/A	6	6	6	6	6	6	6	6
				SHRnom : 1.50			SHRmax : 1.734				

**DIMENSIONS**

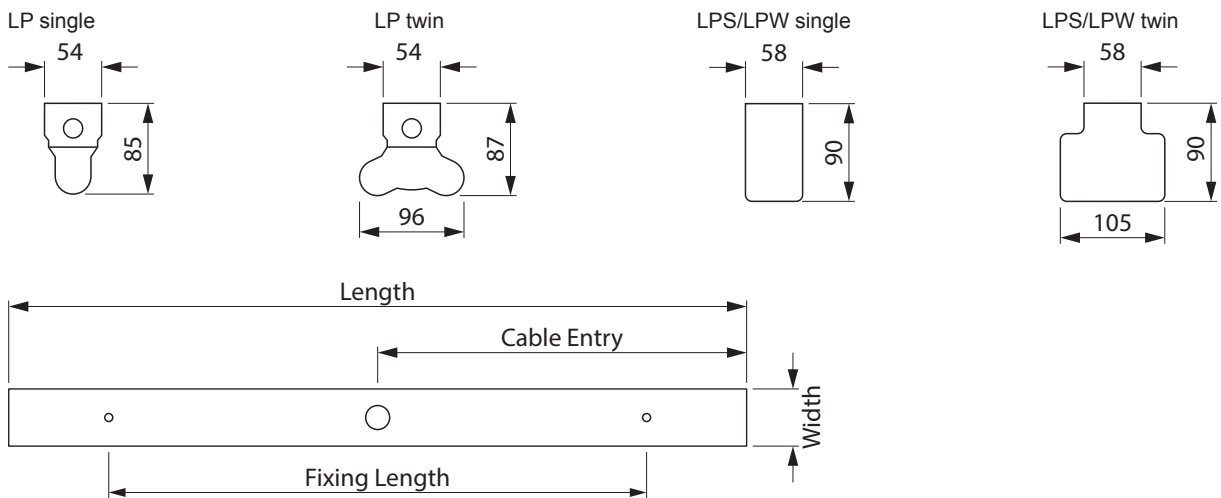

Model	Length	Width	Fixing Width	Cable Entry
LP118EL	LP218EL	609 mm	54 mm	centred
LP130EL	LP230EL	913 mm	54 mm	centred
LP136EL	LP236EL	1218 mm	54 mm	centred
LP158EL	LP258EL	1519 mm	54 mm	centred

**ACCESSORIES**

LPSKxxx	Square diffuser kit
LPWKxxx	Wire guard kit
LPRKxxx	Reflector kit
LPMRKxxx	Mirror reflector kit
LPAKxxx	Angled reflector kit
LPMKxxx	Mirror angled reflector kit

**EMERGENCY MODELS**

LP118ENMEL	1 x 18 W	Non-maintained
LP136ENMEL	1 x 36 W	Non-maintained
LP136EMEL	1 x 36 W	Maintained
LP158ENMEL	1 x 58 W	Non-maintained
LP158EMEL	1 x 58 W	Maintained
LP236EMEL	2 x 36 W	Maintained
LP258EMEL	2 x 58 W	Maintained

Characteristics and specifications may change without notice. All electrical installations / connections should be carried out by a competent person at all times. Application images are indicative only and may not contain actual Davis product. The information contained in this publication is typical and must not be interpreted as a guarantee of individual product performance.

**AUSTRALIA**

HEAD OFFICE: Tel: +61 (7) 3712 8988 Fax: +61 (7) 3272 8988  
 SALES OFFICES (all states): 1300 851 001

E-mail: [australia@davislighting.com](mailto:australia@davislighting.com)  
 Website: [www.davislighting.com](http://www.davislighting.com)