

60cm Freestanding 15 Place

DISHWASHER

PRODUCT CODE: **EDM15XS**



eucooking



Warranty

PRODUCT DIMENSIONS

596mm wide x 598mm depth x 845mm height
(adjustable feet 20mm)

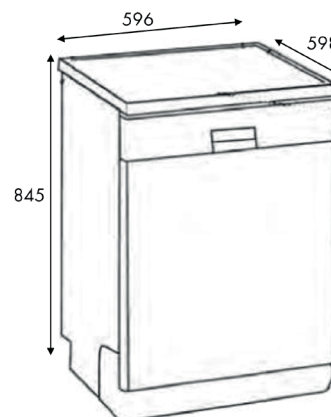

AQUASTOP FLOOD PROTECTION

FEATURES:

- + 15 place setting
- + Stainless steel finish
- + 8 wash programs
 - + Pre Wash
 - + Quick 30 Minutes (40°C)
 - + Economic (50°C)
 - + Super 50 Minutes (60°C)
 - + Daily (60°C)
 - + Auto delicate (30°- 50°C)
 - + Auto (50°- 60°C)
 - + Auto intensive (60°- 70°C)
- + Slide out cutlery basket
- + Delay start function
- + Aqua stop flood protection
- + Finger print resistant
- + Child lock safety
- + Half load function
- + Turbo drying system
- + 2 level height adjustable top basket
- + Concealed heating element
- + Removable top cover (30mm)
- + Water consumption 13.5L (using eco wash)
- + 3.5 star energy rating
- + 4.5 star water rating

SPECIFICATIONS:

Water Consumption	13.5 Litres per wash (using eco program) (4.5 star water rating)
Energy Usage	294 kwh per year (Cold water connection, using ECO program seven times per week) (3.5 star energy rating)
Noise Level	47db
Inlet Hose/Drain Hose Length:	1.5m / 1.7m
Water Connection	Cold water (as dishwasher has its own heating element)
Weight	52.0kg (Gross) / 50.0kg (Net)

KEY FUNCTIONS

15 PLACE SETTINGS

With 15-place settings the EDM15XS provides greater capacity in what types of dishes and cutlery can be washed.

SLIDE OUT CUTLERY RACK

This slide out rack provides an easy and organised way to load your cutlery into the dishwasher.

AQUASTOP FLOOD PROTECTION HOSE

This safety feature will stop the water flow if a leak or reduced water pressure is detected.

8 WASH PROGRAMS

The EDM15XS dishwasher provides you with the choice of 8 different wash programs to ensure you can select the type of wash which best suits whether it be those few dirty dishes or after that large dinner party.

AUTO WASH PROGRAMS

The auto wash programs detect the soiled level of dishes and sets the temperature, amount of water and time required

INSTALLATION INFORMATION

Please refer qualified installer to our product instruction manual.

FILTER CLEANING INFORMATION

Drain pump filter: requires cleaning monthly. This will ensure no interruptions with the dishwasher operation.