

Datasheet

Excel Life™

Switch Mechanism, Secondary Control Push Button

CAT. NO. EM800SLAVEWE, EM800SLAVEUG, EM800SLAVEBL, EM800SLAVEMW, EM800SLAVEMB



Cat. No.	EM800SLAVEWE	EM800SLAVEMW	EM800SLAVEUG	EM800SLAVEBL	EM800SLAVEMB
Colour	White (WE)	Matt White (MW)	Urban Grey (UG)	Black (BL)	Matt Black (MB)
Description	Excel Life Switch Mechanism, Secondary Control Push Button				
Supply voltage	230 - 240 V a.c. 50 Hz				
Dimensions (W x H x D)	21 x 21 x 35 mm				

Excel Life™ Switch Mechanism, Secondary Control Push Button



CAT. NO. EM800SLAVEWE, EM800SLAVEUG, EM800SLAVEBL, EM800SLAVEMW, EM800SLAVEMB



- Soft touch operation
- Mimics the master switch functions (eg. dim or switch)

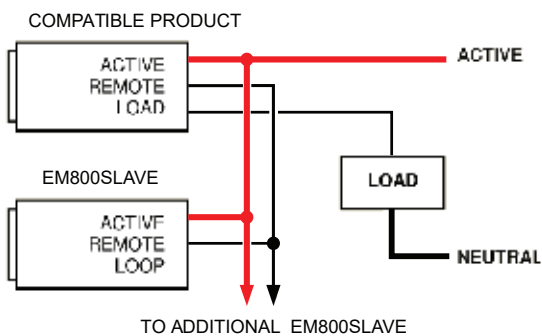

Single product	
Cat. No.	Barcode
EM800SLAVEWE	9321001400196
EM800SLAVEUG	9321001411390
EM800SLAVEBL	9321001452621
EM800SLAVEMW	9321001498285
EM800SLAVEMB	9321001498483

Inner box (QTY 10)		
Cat. No.	Barcode	Dimensions
EM800SLAVEWE	9321001402633	124 x 160 x 80mm
EM800SLAVEUG	9321001412052	
EM800SLAVEBL	9321001453321	
EM800SLAVEMW	9321001498704	
EM800SLAVEMB	9321001498902	

Outer box (QTY 120)		
Cat. No.	Barcode	Dimensions
EM800SLAVEWE	9321001405078	260 x 340 x 260mm
EM800SLAVEUG	9321001412717	
EM800SLAVEBL	9321001454045	
EM800SLAVEMW	9321001499121	
EM800SLAVEMB	9321001499329	

HPM Legrand - AUS
1300 369 777
www.legrand.com.au
ABN 31 000 102 661

HPM Legrand - NZ
0800 476 009
www.legrand.co.nz

Refer to your group buying office, HPM Legrand Sales Representative or HPM Legrand Sales Office for pricing.

HPML0638_B

11/2020