

# MR

**CLICK BASE**  
Slimline Oyster

**M-ELEC**



  
SLIM PROFILE

  
EASY CLICK INSTALL

  
3 CCT OUTPUT

  
DIMMABLE

## Click Base Slimline Oyster

### Product information

With a double insulated body, large terminal block and a quick fit 'click' base makes the M-Elec Click oyster the new go-to product for internal applications (IP20). Coming standard with 3 output colours and dimmable ready the Click oyster range allows for an easy base fit off and a simple slide-to-connect light unit



### TECHNICAL INFORMATION

Data subject to change, please visit our website for up to date specifications: [melec.com.au](http://melec.com.au)

	ML-MRCL-24-M
Total Power	24W*
Lumen Output:	WW 1521LM NW 1794LM W 1622LM
Colour Temp:	3000K (WW)   4000K (NW)   6000K (W)
IP Rating:	IP20
IK Rating:	IK04
CRI:	80
Efficacy:	WW 61LM/W NW 82LM/W W 72LM/W
Beam Angle:	115 degrees
Input Current	0 . 13A
Inrush Current	7A
Dimmable:	Triac dimmable (10-100%)
Power Supply:	Intergrated non - isolated driver
Power Factor	>0 . 9
Frequency	50Hz
Average Life:	30,000hrs**
Dimensions : Base :	Ø300 X 300 X 45MM
Weight	0.42kg
Operating Temp	-10°C to 40°C
Compliance	SAA
Connection	PA16 Terminal block
LED Chip Brand	SMD2835
Materials:	ABS body and PMMA diffuser

\*Total power consumed including driver

\*\* Average life is calculated on expected average lifespan

## INSTALLATION GUIDE

1. Ensure all power is off before beginning installation.
2. Remove bracket from fitting (A).
3. Install bracket onto ceiling using appropriate fixing methods (B).
4. Terminate bracket according to wiring diagram (C).
5. Select colour output on the CCT switch locate on the side wall of the fitting (D).
6. Slide bracket onto the fitting ensuring to properly mate with the guide rails (E).
7. Slide the bracket onto the fitting until an audible click is heard, signifying proper connection of the click oyster to the bracket's terminal box (F).
8. Test the safety and operation in accordance with all standards.

### WIRING DIAGRAM

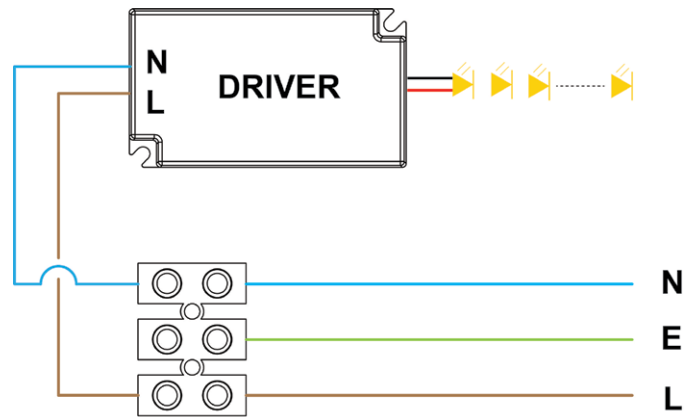

(A)

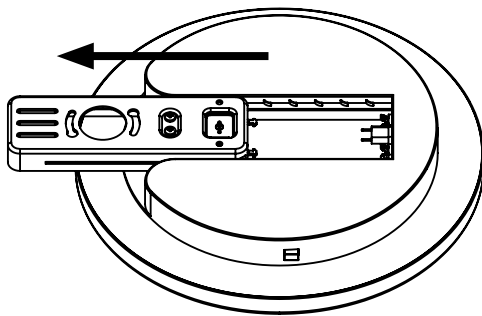

(B)

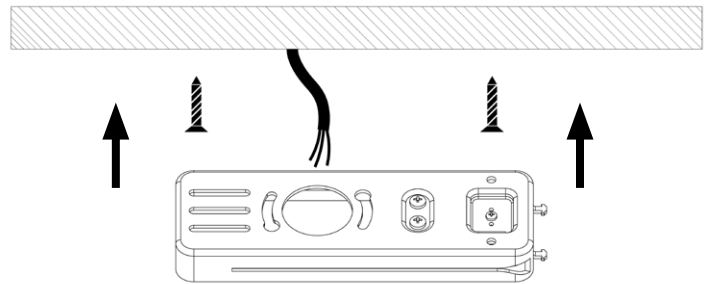

(C)

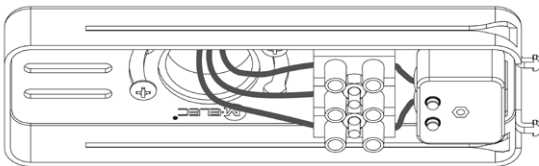

(D)

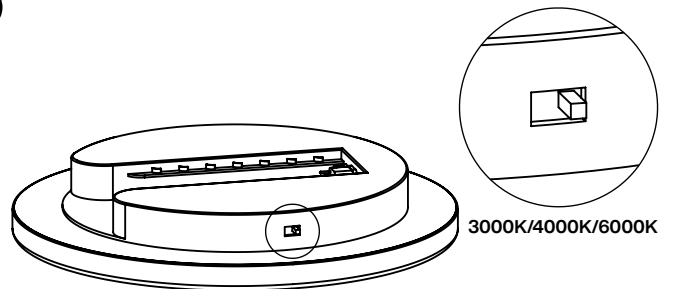

(E)

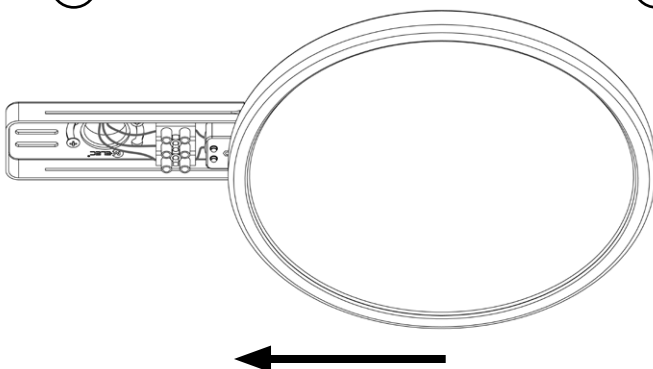

(F)

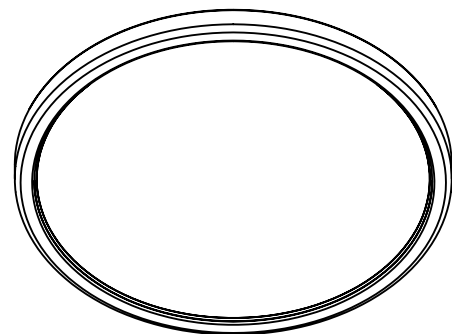

## INSTALLATION GUIDE - REMOVAL

1. Ensure all power is off before beginning removal.
2. Push the fitting against the bracket until an audible click is heard (Ensure that this is parallel with the bracket) (A)
3. Slowly slide the fitting away from the bracket to complete removal. (B)

**NOTE:** Do not pull the fitting off from the bracket without first pushing it back into the bracket to release the locking mechanism.

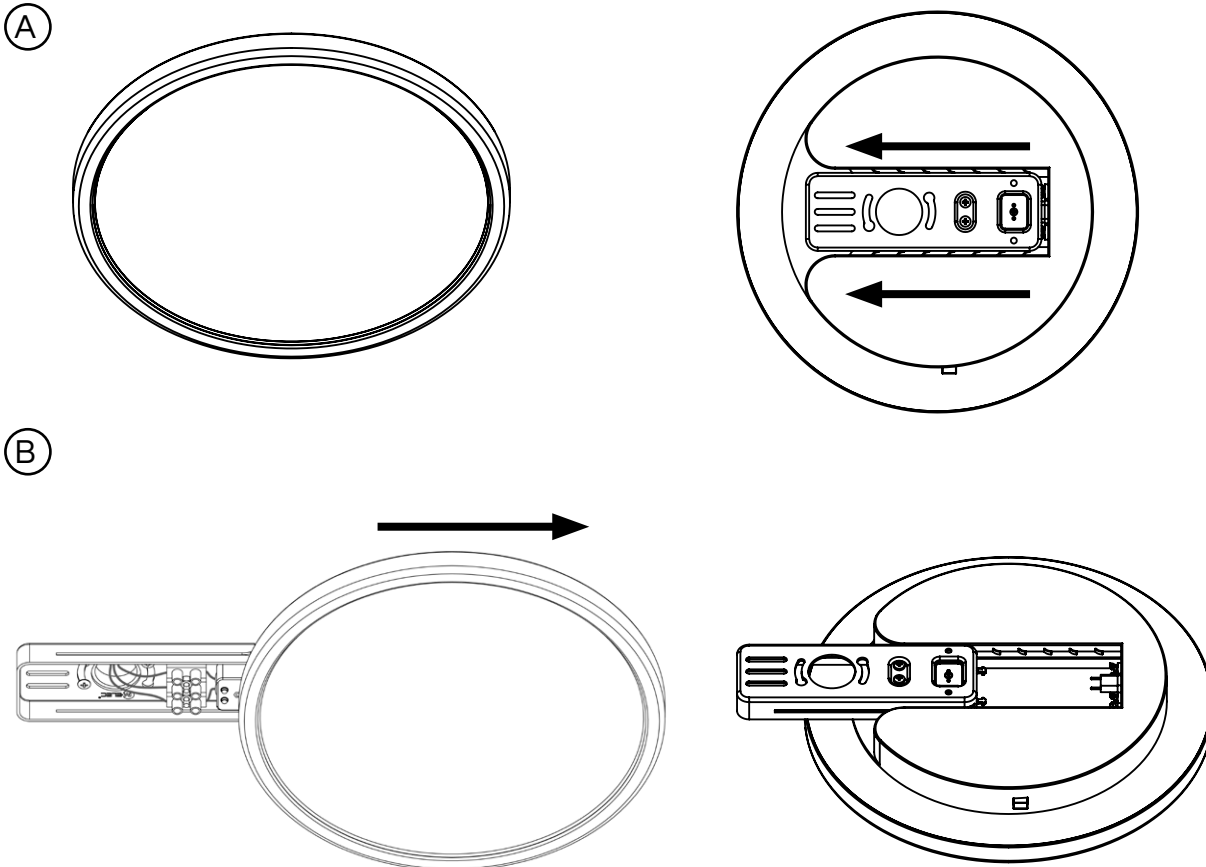

**NOTE:** In the event you notice that the push locking mechanisms of the fitting are mismatched, push the un-even connector back into itself until it releases back out to the correct position.

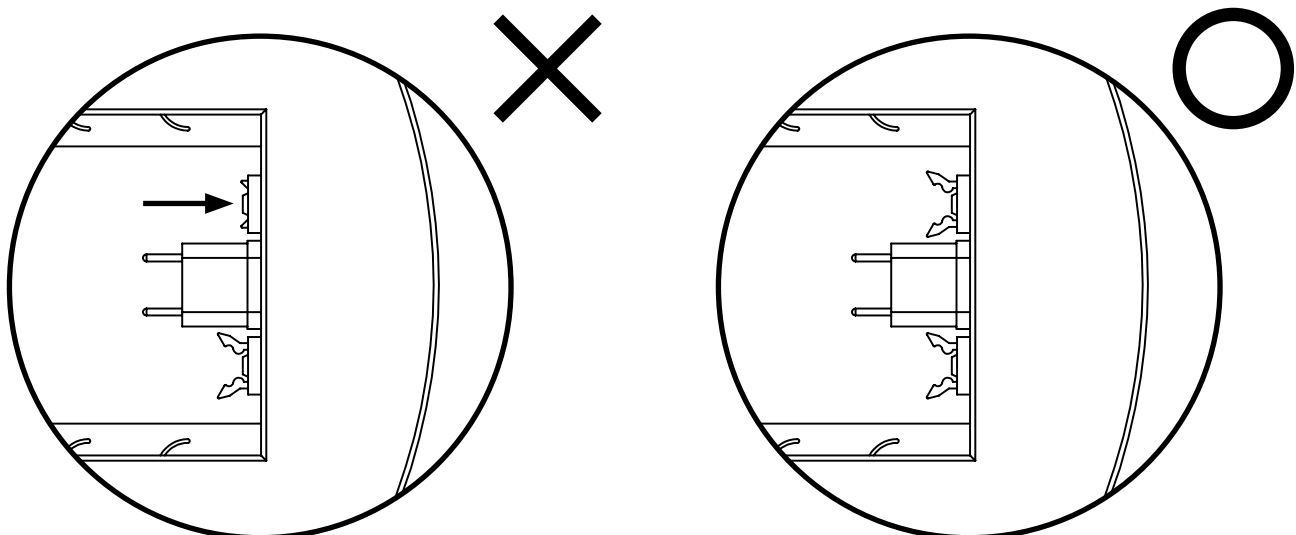

## PRODUCT DIMENSIONS

---

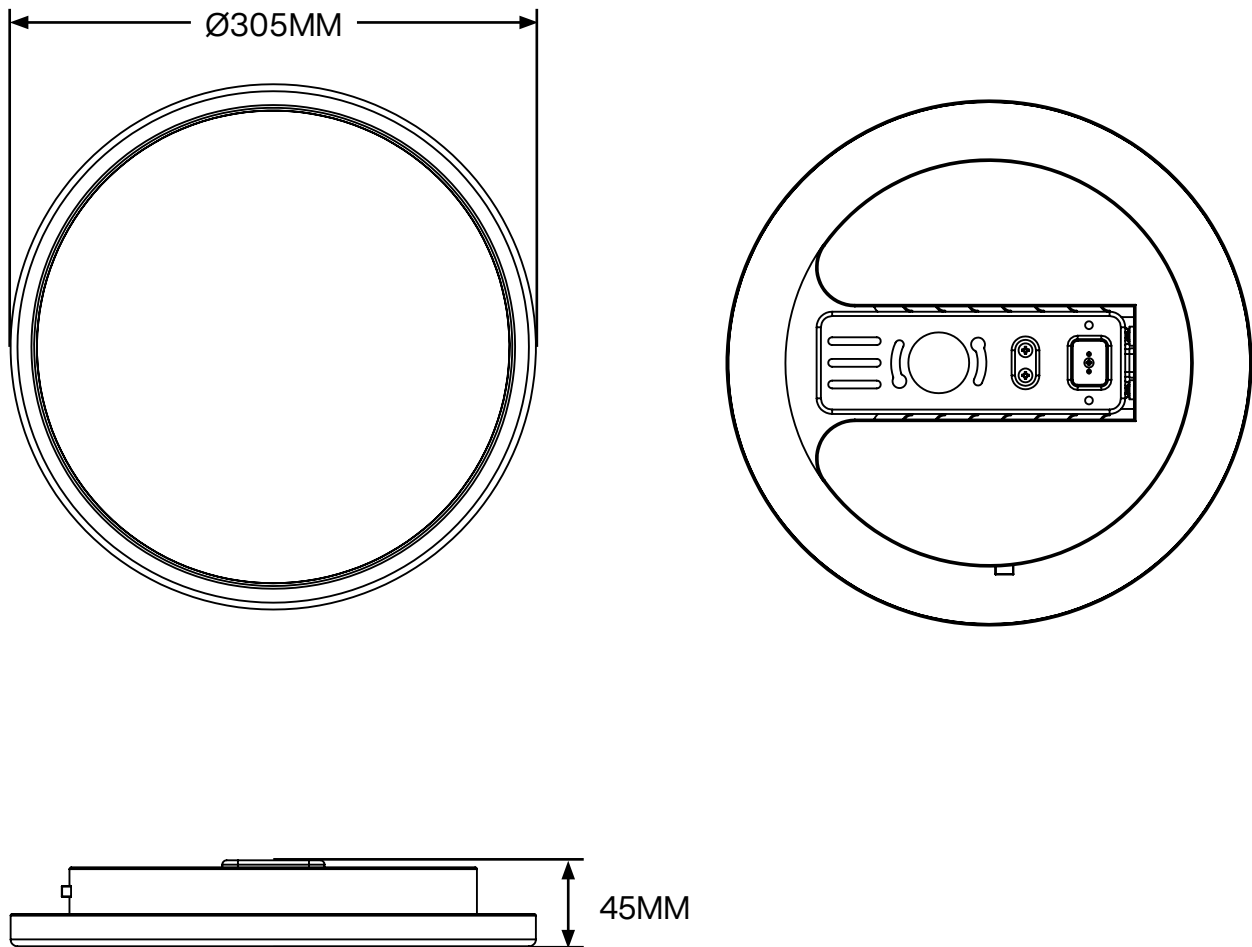

## PLEASE NOTE

---

MUST BE INSTALLED BY A LICENSED ELECTRICIAN

- Read instructions carefully before attempting to install the fitting. Retain this guide for future reference
- Disconnect power before installing or servicing
- Do not extend low voltage cables from the output of power supply
- All components must not be mechanically stressed
- Be careful not to damage or destroy conductive paths on the circuit board
- Follow all relevant electrical and safety standards (including AS3000)
- Correct electrical polarity must be observed as the wrong polarity may destroy the product and is not covered under warranty
- Damage by corrosion will not be honoured as a material defect claim. It is the user's responsibility to provide suitable protection against corrosive agents such as moisture, condensation and other harmful elements

**FREE**  
**ONSITE WARRANTY**

EXCLUSIVE TO  
MEMBERS ONLY



**FREE ONSITE WARRANTY FOR 3 YEARS**  
**INCLUDES PARTS & LABOUR**

---

*In conjunction with your standard product warranty*