

# MiCOM H35x

Ethernet Switches

H35x/EN GL/C24

Global Documentation



# CONTENTS

---

<b>1.</b>	<b>SAFETY AND HANDLING</b>	<b>5</b>
1.1	Health and safety	5
1.2	Symbols	6
1.3	Installing, commissioning and servicing	6
1.4	De-commissioning and disposal	7
1.5	Technical specifications for safety	8
1.5.1	Protective fuse rating	8
1.5.2	Protective class	8
1.5.3	Installation category	8
1.5.4	Environment	8
1.6	Handling of Electronic Equipment	8
1.7	Packing and Unpacking	9
1.8	Guarantees	9
1.9	Copyrights & Trademarks	10
1.9.1	Copyrights	10
1.9.2	Trademarks	10
1.9.3	Warnings regarding use of Schneider Electric products	10

---

<b>2.</b>	<b>INTRODUCTION</b>	<b>11</b>
2.1	MiCOM Switches	11
2.2	MiCOM Ethernet Switch names	11
2.3	MiCOM H35x	11

---

<b>3.</b>	<b>FUNCTIONAL DESCRIPTION</b>	<b>12</b>
3.1	MiCOM H35x Product Range	12
3.2	Fast redundant ring capability	12
3.2.1	Self-healing ring principle	12
3.2.2	MiCOM Hx5x Ethernet switch with self-healing ring facilities	13
3.2.3	Schneider Electric Ethernet ring redundancy	13
3.2.4	Performance	14
3.2.5	Benefits	15
3.3	MiCOM H35x functional composition	15
3.4	Power management	15
3.5	Ethernet Port Switching Features	15
3.5.1	10Base Tx and 100Base Tx	15
3.5.2	100Base Fx	15

<b>3.6</b>	<b>Ethernet Management</b>	<b>16</b>
3.6.1	Address lookup	16
3.6.2	Auto-negotiation and speed-sensing	16
3.6.3	Forwarding	16
3.6.4	Priority tagging	16
3.6.5	SNMP v2	16
<hr/>		
<b>4.</b>	<b>TECHNICAL DATA</b>	<b>18</b>
<b>4.1</b>	<b>MiCOM H35x Range</b>	<b>18</b>
<b>4.2</b>	<b>CONFORMITY</b>	<b>18</b>
<b>4.3</b>	<b>Ethernet Port Characteristics</b>	<b>18</b>
4.3.1	10/100BaseTx Port	18
4.3.2	100BaseFx Multimode Port (H352)	18
4.3.3	100BaseFx Single Mode Port (H354)	18
<b>4.4</b>	<b>General Characteristics</b>	<b>19</b>
4.4.1	Mechanical	19
4.4.2	Auxiliary Power Supply	19
4.4.3	Auxiliary Fault Relay	19
4.4.4	Ethernet Management	19
<b>4.5</b>	<b>Environmental Characteristics</b>	<b>20</b>
4.5.1	Electrical	20
4.5.2	Isolation	20
4.5.3	Climatic	20
4.5.4	Electromagnetic Compatibility	21
4.5.5	Mechanical	21
<hr/>		
<b>5.</b>	<b>HUMAN MACHINE INTERFACE (HMI)</b>	<b>22</b>
<b>5.1</b>	<b>H352-V2 HMI</b>	<b>22</b>
<b>5.2</b>	<b>H356/H358 HMI</b>	<b>22</b>
<b>5.3</b>	<b>H35x LEDs</b>	<b>23</b>
<hr/>		
<b>6.</b>	<b>INSTALLATION</b>	<b>24</b>
<hr/>		
<b>7.</b>	<b>CONNECTION</b>	<b>25</b>
<b>7.1</b>	<b>Connection of the protective conductor (earth)</b>	<b>25</b>
<b>7.2</b>	<b>Cable fitting</b>	<b>25</b>
<b>7.3</b>	<b>Power supply wiring</b>	<b>26</b>
<b>7.4</b>	<b>Fail-safe contacts</b>	<b>27</b>
<b>7.5</b>	<b>Ethernet Connection</b>	<b>28</b>
7.5.1	Ethernet cable type	28
7.5.2	Ethernet optical fiber	28

---

<b>8.</b>	<b>SETTINGS</b>	<b>30</b>
8.1	Dip switch description	30
8.2	Address of the repeater	30
8.2.1	Configuring the address	30
8.2.2	Example: defining address "10"	30
8.3	IP Address of the repeater	31
8.4	Power supply alarm	31
8.5	Label	31

---

<b>9.</b>	<b>MAINTENANCE</b>	<b>32</b>
9.1	Scope	32
9.2	Recommendation before maintenance operations	32
9.3	Maintenance period	32
9.4	Diagnosis facilities	33
9.5	Method of repair	33
9.5.1	Replacing the MiCOM H3xx	33

---

<b>10.</b>	<b>APPLICATIONS</b>	<b>34</b>
10.1	Fiber Optic budget calculations	34
10.1.1	Example 1: between repeaters	35
10.1.2	Example 2: between repeaters with patch panel	35

---

<b>11.</b>	<b>GLOSSARY</b>	<b>36</b>
------------	-----------------	-----------

## FIGURES

FIGURE 1: SELF-HEALING RING MECHANISM	12
FIGURE 2: INTERNAL ARCHITECTURE OF MiCOM HX5X	13
FIGURE 3: NOMINAL REDUNDANT ETHERNET RING ARCHITECTURE WITH MiCOM HX5X SWITCHES	14
FIGURE 4: ETHERNET RING ARCHITECTURE WITH MiCOM HX5X SWITCHES AFTER FAILURE	14
FIGURE 5: MiCOM H352	15
FIGURE 6: H35X MIB STRUCTURE	16
FIGURE 7: 10/100BASETX PORT	18
FIGURE 8: 100BASEFX MULTIMODE PORT (H352)	18
FIGURE 9: 100BASEFX SINGLE MODE PORT (H354)	18
FIGURE 10: H352-V2 HMI	22
FIGURE 11: H356/H358 HMI	22
FIGURE 12: EARTHING CABLE EXAMPLE	25
FIGURE 13: POWER SUPPLY WIRING	26
FIGURE 14: FAIL-SAFE CONTACTS WIRING	27
FIGURE 15: RJ45 CONNECTOR	28
FIGURE 16: ETHERNET OPTICAL FIBER – ST	28
FIGURE 17: ETHERNET OPTICAL FIBER – SC	29
FIGURE 18: DIP SWITCHES	30
FIGURE 19: DIP SWITCHES EXAMPLE	31
FIGURE 20: IP ADDRESS	31
FIGURE 21: MiCOM H35X LABEL	31
FIGURE 22: POWER SUPPLY CONNECTOR	32
FIGURE 23: FIBER BUDGET	34
FIGURE 24: FIBER BUDGET EXAMPLE	34

---

## 1. SAFETY AND HANDLING

This Safety Section and the relevant equipment documentation provide full information on safe handling, commissioning and testing of this equipment.

The technical data in this Safety Section is typical only, see the technical data section of the relevant equipment documentation for data specific to a particular piece of equipment.



Before carrying out any work on the equipment the user should be familiar with the contents of this Safety Section and the ratings on the equipment's rating label.

Reference should be made to the external connection diagram before the equipment is installed, commissioned or serviced.

### 1.1 Health and safety

The information in the Safety Section of the equipment documentation is intended to ensure that the equipment is properly installed and handled in order to maintain it in a safe condition.

It is assumed that everyone who will be associated with the equipment will be familiar with the contents of this Safety Section.

When electrical equipment is in operation, dangerous voltages will be present in certain parts of the equipment. Failure to observe warning notices, incorrect use, or improper use may endanger personnel and equipment and also cause personal injury or physical damage.

Before working on the equipment it must first be electrically isolated.

Proper and safe operation of the equipment depends on appropriate shipping and handling, proper storage, installation and commissioning, and on careful operation, maintenance and servicing. For this reason only qualified personnel may work on or operate the equipment.





Qualified personnel are individuals who:

- Are familiar with the installation, commissioning, and operation of the equipment and of the system to which it is being connected;
- Are trained in the care and use of safety apparatus in accordance with safety engineering practices;
- Are trained in emergency procedures (first aid).

The equipment documentation gives instructions for its installation, commissioning, and operation. However, the manuals cannot cover all conceivable circumstances or include detailed information on all topics. In the event of questions or specific problems, do not take any action without proper authorization. Contact the appropriate Schneider Electric technical sales office and request the necessary information.

## 1.2 Symbols

For safety reasons the following symbols which may be used on the equipment or referred to in the equipment documentation, should be understood before it is installed or commissioned.

	
Caution: refer to equipment documentation	Caution: risk of electric shock
	
Protective Conductor (*Earth) terminal	Functional/Protective Conductor (*Earth) terminal
	Note: This symbol may also be used for a Protective Conductor (Earth) terminal if that terminal is part of a terminal block or sub-assembly e.g. power supply.

\*NOTE: THE TERM EARTH USED THROUGHOUT THIS TECHNICAL MANUAL IS THE DIRECT EQUIVALENT OF THE NORTH AMERICAN TERM GROUND.

## 1.3 Installing, commissioning and servicing



### Equipment connections

Personnel undertaking installation, commissioning or servicing work for this equipment should be aware of the correct working procedures to ensure safety.

The equipment documentation should be consulted before installing, commissioning, or servicing the equipment.

Terminals exposed during installation, commissioning and maintenance may present a hazardous voltage unless the equipment is electrically isolated.

Any disassembly of the equipment may expose parts at hazardous voltage, also electronic parts may be damaged if suitable electrostatic voltage discharge (ESD) precautions are not taken.

If there is unlocked access to the rear of the equipment, care should be taken by all personnel to avoid electric shock or energy hazards.

The equipment must be connected in accordance with the appropriate connection diagram.

#### Protection Class I Equipment

- Before energizing the equipment it must be earthed using the protective conductor terminal, if provided, or the appropriate termination of the supply plug in the case of plug connected equipment.
- The protective conductor (earth) connection must not be removed since the protection against electric shock provided by the equipment would be lost.
- When the protective (earth) conductor terminal (PCT) is also used to terminate cable screens, etc., it is essential that the integrity of the protective (earth) conductor is checked after the addition or removal of such functional earth connections. For M4 stud PCTs the integrity of the protective (earth) connections should be ensured by use of a locknut or similar.



The recommended minimum protective conductor (earth) wire size is 2.5 mm<sup>2</sup> (3.3 mm<sup>2</sup> for North America) unless otherwise stated in the technical data section of the equipment documentation, or otherwise required by local or country wiring regulations.

The protective conductor (earth) connection must be low-inductance and as short as possible.

Before energizing the equipment, the following should be checked:

- Voltage rating/polarity (rating label/equipment documentation);
- Protective fuse rating;
- Integrity of the protective conductor (earth) connection (where applicable);
- Voltage rating of external wiring, applicable to the application.



#### **Equipment use**

If the equipment is used in a manner not specified by the manufacturer, the protection provided by the equipment may be impaired.



#### **Equipment operating conditions**

The equipment should be operated within the specified electrical and environmental limits.



#### **Insulation and dielectric strength testing**

Insulation testing may leave capacitors charged up to a hazardous voltage. At the end of each part of the test, the voltage should be gradually reduced to zero, to discharge capacitors, before the test leads are disconnected.



#### **Insertion of modules and PCB cards**

Modules and PCB cards must not be inserted into or withdrawn from the equipment whilst it is energized, since this may result in damage.



#### **Fiber optic communication**

Where fiber optic communication devices are fitted, these should not be viewed directly. Optical power meters should be used to determine the operation or signal level of the device.



#### **Cleaning**

The equipment may be cleaned using a lint-free cloth dampened with clean water, when no connections are energized. Contact fingers of test plugs are normally protected by petroleum jelly, which should not be removed.

### **1.4 De-commissioning and disposal**



#### **De-commissioning**

The supply input (auxiliary) for the equipment may include capacitors across the supply or to earth. To avoid electric shock or energy hazards, after completely isolating the supplies to the equipment (both poles of any dc supply), the capacitors should be safely discharged via the external terminals prior to de-commissioning.



#### **Disposal**

It is recommended that incineration and disposal to water courses is avoided. The equipment should be disposed of in a safe manner. Any equipment containing batteries should have them removed before disposal, taking precautions to avoid short circuits. Particular regulations within the country of operation, may apply to the disposal of the equipment.

## 1.5 Technical specifications for safety

Unless otherwise stated in the equipment technical manual, the following data is applicable.

### 1.5.1 Protective fuse rating

The recommended maximum rating of the external protective fuse for equipments is 16A, high rupture capacity (HRC) Red Spot type NIT, or TIA, or equivalent. The protective fuse should be located as close to the unit as possible.

### 1.5.2 Protective class

IEC 60255-27: 2005  
EN 60255-27: 2005

Class I (unless otherwise specified in the equipment documentation). This equipment requires a protective conductor (earth) connection to ensure user safety.

### 1.5.3 Installation category

IEC 60255-27: 2005  
EN 60255-27: 2005

Installation category III (Overvoltage Category III):  
Distribution level, fixed installation.

Equipment in this category is qualification tested at 5 kV peak, 1.2/50  $\mu$ s, 500  $\Omega$ , 0.5 J, between all supply circuits and earth and also between independent circuits.

### 1.5.4 Environment

The equipment is intended for indoor installation and use only. If it is required for use in an outdoor environment then it must be mounted in a specific cabinet or housing allowing it to meet the requirements of IEC 60529 with the classification of degree of protection IP54 (dust and splashing water protected).

Pollution Degree - Pollution Degree 2  
Altitude - Operation up to 2000m

Compliance is demonstrated by reference to safety standards.

IEC 60255-27:2005  
EN 60255-27: 2005

## 1.6 Handling of Electronic Equipment

A person's normal movements can easily generate electrostatic potentials of several thousand volts.

Discharge of these voltages into semiconductor devices when handling circuits can cause serious damage, which often may not be immediately apparent but the reliability of the circuit will have been reduced.

The electronic circuits of Schneider Electric products are immune to the relevant levels of electrostatic discharge when housed in their cases. Do not expose them to the risk of damage by withdrawing modules unnecessarily.

Each module incorporates the highest practical protection for its semiconductor devices. However, if it becomes necessary to withdraw a module, the following precautions should be taken in order to preserve the high reliability and long life for which the equipment has been designed and manufactured.

1. Before removing a module, ensure that you are at the same electrostatic potential as the equipment by touching the case.
2. Handle the module by its front-plate, frame, or edges of the printed circuit board. Avoid touching the electronic components, printed circuit track or connectors.
3. Do not pass the module to any person without first ensuring that you are both at the same electrostatic potential. Shaking hands achieves equipotential.
4. Place the module on an antistatic surface, or on a conducting surface that is at the same potential as you.
5. Store or transport the module in a conductive bag.

More information on safe working procedures for all electronic equipment can be found in IEC 60147-0F and BS5783.

If you are making measurements on the internal electronic circuitry of any equipment in service, it is preferable that you are earthed to the case with a conductive wrist strap.

Wrist straps should have a resistance to ground between 500k – 10M Ohms. If a wrist strap is not available you should maintain regular contact with the case to prevent the build up of static. Instruments used for making measurements should be earthed to the case whenever possible.

Schneider Electric strongly recommends that detailed investigations on the electronic circuitry, or modification work, should be carried out in a Special Handling Area such as described in IEC 60147-0F or BS5783.

## 1.7 Packing and Unpacking

All MiCOM Hxxx devices are packaged separately in their own cartons and shipped inside outer packaging. Use special care when opening the cartons and unpacking the device, and do not use force. In addition, make sure to remove from the inside carton the supporting documents supplied with each individual device and the type identification label.

The design revision level of each module included with the device in its as-delivered condition can be determined from the list of components. This list should be carefully saved.

After unpacking the device, inspect it visually to make sure it is in proper mechanical condition.

If the MiCOM Hxxx device needs to be shipped, both inner and outer packaging must be used. If the original packaging is no longer available, make sure that packaging conforms to ISO 2248 specifications for a drop height  $\leq 0.8\text{m}$ .

## 1.8 Guarantees

The media on which you received Schneider Electric software is guaranteed not to fail executing programming instructions, due to defects in materials and workmanship, for a period of 90 days from date of shipment, as evidenced by receipts or other documentation. Schneider Electric will, at its option, repair or replace software media that do not execute programming instructions if Schneider Electric receive notice of such defects during the warranty period. Schneider Electric does not guarantee that the operation of the software shall be uninterrupted or error free.

A Return Material Authorization (RMA) number must be obtained from the factory and clearly marked on the package before any equipment acceptance for guarantee work. Schneider Electric will pay the shipping costs of returning to the owner any parts that are covered by warranty.

Schneider Electric believe that the information in this document is accurate. The document has been carefully reviewed for technical accuracy. In the event that technical or typographical errors exist, Schneider Electric reserves the right to make changes to subsequent editions of this document without prior notice to holders of this edition. The reader should consult Schneider Electric if errors are suspected. In no event shall Schneider Electric be liable for any damages arising from or related to this document or the information contained in it.

Except as specified herein, Schneider Electric makes no guarantees, express or implied and specifically disclaims any guarantee of merchantability or suitability for a particular purpose. Customer's rights to recover damages caused by fault or negligence on the part Schneider Electric shall therefore be limited to the amount paid by the customer. Schneider Electric will not be liable for damages resulting from loss of data, profits, use of products or incidental or consequential damages even if advised of the possibility thereof. This limitation of the liability of Schneider Electric will apply regardless of the form of action, whether in contract or tort, including negligence. Any action against Schneider Electric must be brought within one year after the cause of action accrues. Schneider Electric shall not be liable for any delay in performance due to causes beyond its reasonable control. The warranty provided herein does not cover damages, defects, malfunctions, or service failures caused by owner's failure to follow Schneider Electric installation, operation, or maintenance instructions, owner's modification of the product; owner's abuse, misuse, or negligent acts;

and power failure or surges, fire, flood, accident, actions of third parties, or other events outside reasonable control.

## **1.9 Copyrights & Trademarks**

### **1.9.1 Copyrights**

Under the copyright laws, this publication may not be reproduced or transmitted in any form, electronic or mechanical, including photocopying, recording, storing in an information retrieval system, or translating, in whole or in part, without the prior written consent of Schneider Electric.

### **1.9.2 Trademarks**

PACiS, PACiS SCE, PACiS OI, PACiS SMT, Schneider Electric are trademarks of Schneider Electric. Product and company names mentioned herein are trademarks or trade names of their respective companies.

### **1.9.3 Warnings regarding use of Schneider Electric products**

Schneider Electric products are not designed with components and testing for a level of reliability suitable for use in connection with surgical implants or as critical components in any life support systems whose failure to perform can reasonably be expected to cause significant injuries to a human.

In any application, including the above reliability of operation of the software products can be impaired by adverse factors, including - but not limited to - fluctuations in electrical power supply, computer hardware malfunctions, computer operating system malfunctions, software suitability, suitability of compilers and development software used to develop an application, installation errors, software and hardware compatibility problems, malfunctions or failures of electronic monitoring or control devices, transient failures of electronic systems (hardware and/or software), unanticipated uses or misuses, or errors by the user or application designer (adverse factors such as these are collectively termed "System failures").

Any application where a system failure would create a risk of harm to property or persons (including the risk of bodily injuries and death) should not be reliant solely upon one form of electronic system due to the risk of system failure to avoid damage, injury or death, the user or application designer must take reasonable steps to protect against system failure, including - but not limited - to back-up or shut-down mechanisms, not because the end-user's system is customized and differs from Schneider Electric testing platforms but also because a user or application designer may use Schneider Electric products in combination with other products.

These actions cannot be evaluated or contemplated by Schneider Electric. Thus, the user or application designer is ultimately responsible for verifying and validating the suitability of Schneider Electric products whenever they are incorporated in a system or application, even without limitation of the appropriate design, process and safety levels of such system or application.

---

## 2. INTRODUCTION

The MiCOM Ethernet range is designed to deal with the needs of a wide range of electric plants. Emphasis has been placed on strong compliance with standards, scalability, modularity and open architecture.

These features facilitate the use of MiCOM products in several applications, from the most basic to the most demanding. They also ensure interoperability with existing components.

Schneider Electric philosophy is to provide a range of Ethernet products such as switches, taking into account the compulsory requirements of electrical substations, including power supply and immunity to environmental constraints.

It also provides solutions to specific requirements such as network redundancy management.

Each of these products can be used independently, or can be integrated to form a PACiS system, which is a Digital Control System (DCS).

### 2.1 MiCOM Switches

Driven by calls from all over the world for advanced substation applications for Automation control and monitoring, Schneider Electric is committed to provide a comprehensive range of Ethernet-based products that respond to our customers' needs.

Standard Ethernet products rarely meet the constraints of electrical plants: environmental, power supply, redundancy, etc.

The new MiCOM Hxxx series has been specially tailored to respond to all of these requirements, and is compatible with the PACiS system. The MiCOM Hxxx range is designed to address different kinds of architectures and installations.

### 2.2 MiCOM Ethernet Switch names

Basically the naming of Ethernet devices is composed of its mechanical arrangement and its number of port copper or optical.

- MiCOM H3xx DIN mounting case and Redundant power supply

### 2.3 MiCOM H35x

The MiCOM H35x range is a set of standalone switches, embedded with the Self Healing Mechanism to provide redundancy.

The MiCOM H35x range relies on managed switches that are easy to install and operate, designed to be implemented in an electrical plant environment (IEC 61000-4 & 60255-5).

On the media side, MiCOM H35x supports 10BaseT, 100BaseTX and 100BaseFX as specified by the IEEE 802.3 standard.

The MiCOM H35x is a plug-and-play device. It can run with the factory settings. However, to adapt the switch to your application, you only need to configure the switch number using the DIP switches. (see chapter 8: Settings).

### 3. FUNCTIONAL DESCRIPTION

The MiCOM H35x is designed to be an Ethernet switch with a DIN RAIL mounting.

#### 3.1 MiCOM H35x Product Range

The MiCOM H35x range is dedicated to ultra fast redundant Ethernet rings, and is defined by the type of Ethernet connector. All the MiCOM H35x equipment range has at least two copper connections via RJ45 connectors, with speed automatically adjusted by the external emitters to 10 or 100 Mbps.

Ethernet copper links are limited in distance and subject to interference. The redundant Ethernet ring is based on optical inter-switch connection. The user has the choice between using Multimode Fiber optic for short distances, or Single mode Fiber Optic for long distances.

The table below describes the MiCOM H35x range, detailing the connectivity used.

Model	Description	Connectors
MiCOM H 352	Fast Ethernet industrial switch Multimode 1310 nm	6 x RJ45 2 x ST (for Ring)
MiCOM H 354	Fast Ethernet industrial switch Single mode 1310 nm	6 x RJ45 2 x SC

#### 3.2 Fast redundant ring capability

##### 3.2.1 Self-healing ring principle

Ethernet redundancy is usually managed by protocols that calculates another path to a destination (by sending BPDUs) when the main link breaks. This could take from hundreds of milliseconds to seconds. But the automation processes and applications require a network reconfiguration of the order of 1 millisecond.

The Schneider Electric self-healing mechanism fulfils automation requirements by delivering a very fast recovery time for the entire network (<1 ms).

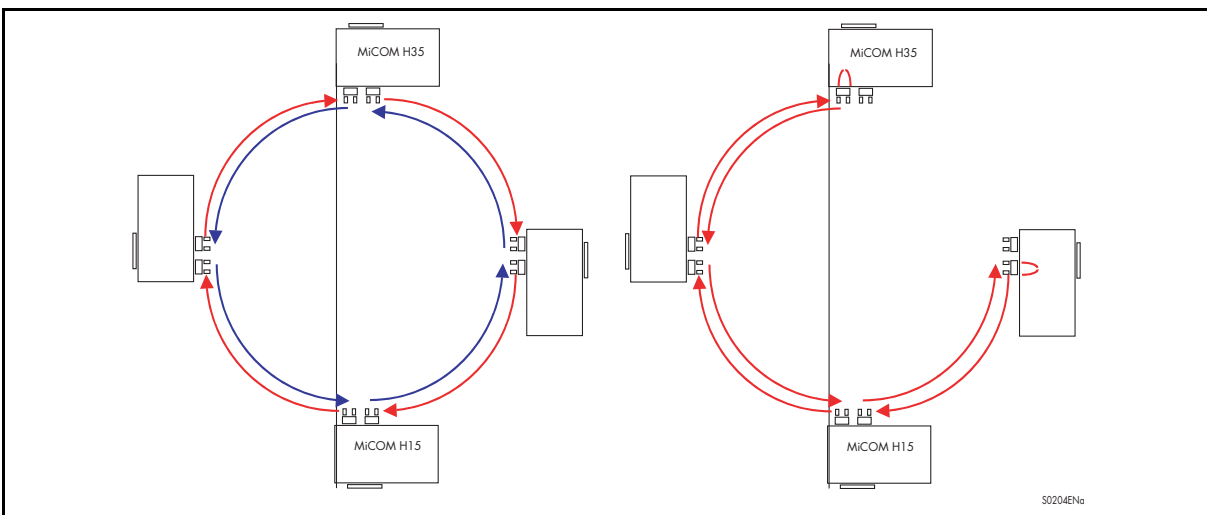

FIGURE 1: SELF-HEALING RING MECHANISM

### 3.2.2 MiCOM Hx5x Ethernet switch with self-healing ring facilities

The MiCOM Hx5x is a standard IEEE802.3 Ethernet switch enhanced with the self-healing manager (SHM). The diagram below shows the internal architecture of such a device.

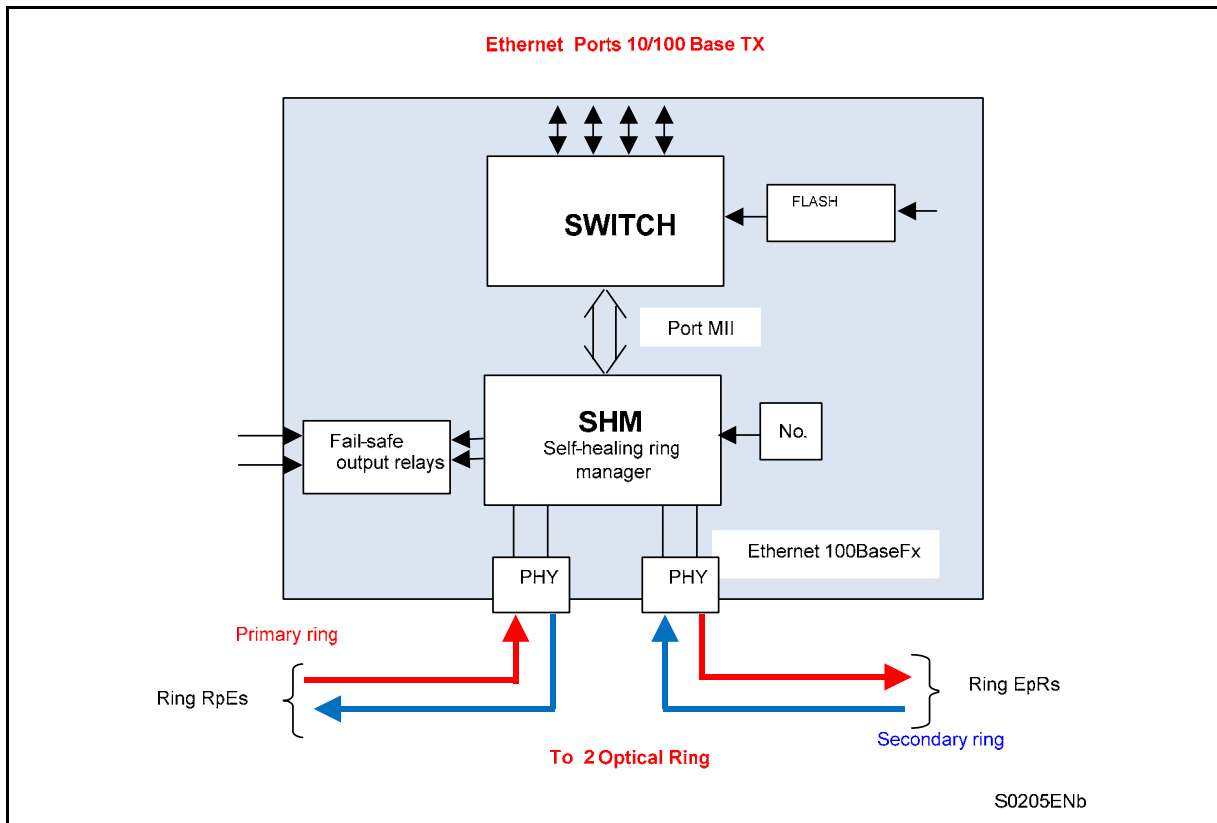

FIGURE 2: INTERNAL ARCHITECTURE OF MiCOM HX5X

### 3.2.3 Schneider Electric Ethernet ring redundancy

The SHM functions manage the ring. If the connection between two devices is broken the network continues to run correctly.

Normally Ethernet packets travel on the primary fiber in the same direction, and only a control frame (4 bytes) is sent every 5  $\mu$ s on the secondary fiber in the opposite direction.

If the link is down, both SHMs immediately start the network self-healing. On one side of the break, received messages are no longer sent to the primary fiber but are sent to the secondary fiber. On the other side of the break, messages received on the secondary fiber are sent to the primary fiber and the new topological loop is closed in less than 1 ms.

It is therefore possible to extend the number of devices, or the size of a substation without stopping the network. The loop is opened and new equipment is connected (which closes the loop).

To increase reliability, some specific mechanisms are used:

- The quality of transmission is monitored. Each frame (Ethernet packet or control frame) is controlled by the SHM. If a high error rate is detected, self-healing starts and the fault is eliminated.
- Even if there is no traffic on the primary link, the secondary link is still supervised by sending out control frames every 5  $\mu$ s.

Initially, the network architecture is as shown on figure 3.

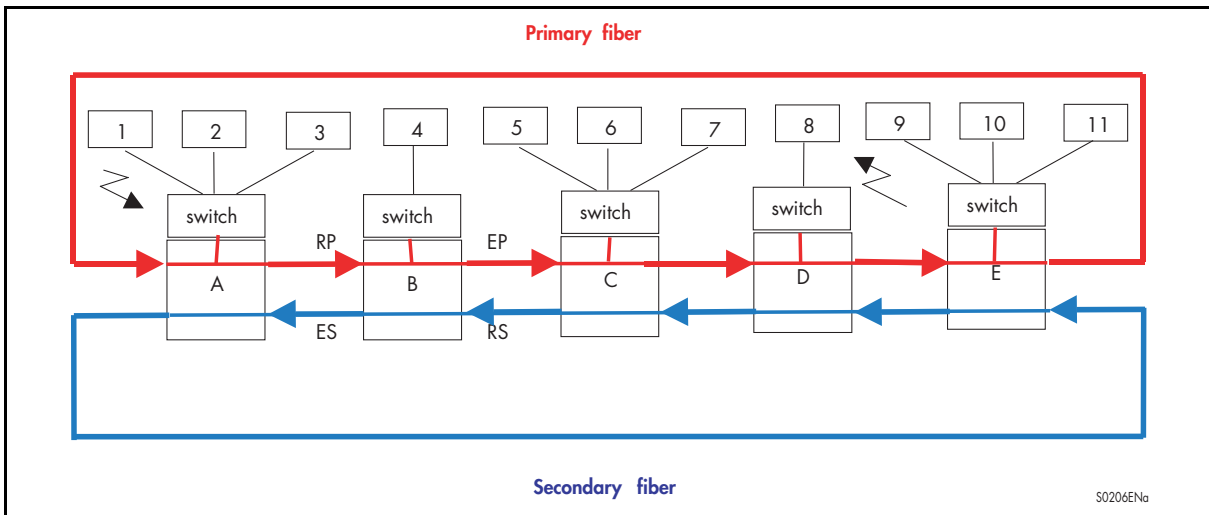

FIGURE 3: NOMINAL REDUNDANT ETHERNET RING ARCHITECTURE WITH MiCOM HX5X SWITCHES

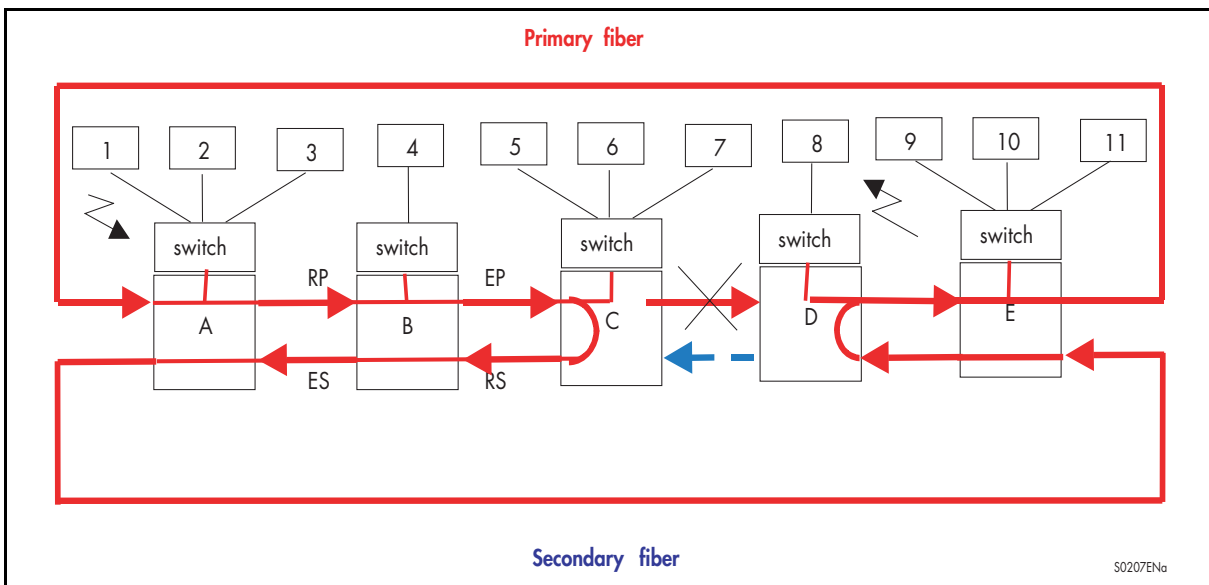

FIGURE 4: ETHERNET RING ARCHITECTURE WITH MiCOM HX5X SWITCHES AFTER FAILURE

3.2.4 Performance

To calculate the time end to end, use the following table based on the nominal situation:

Send a Goose frame from... to...	Time at 100 Mbps	Abbr.	Comments
IED 1 to Switch A	22 μs		262 bytes + inter-frame
Switch A to IED 2	22 μs		Store and forward mechanism
Switch A to the network	2 μs	tl	Repeater latency time
Propagation time to the fiber	μs		4.8 μs /km
Network to network	2 μs	tl	Repeater latency time

When the frame circulates on the ring, the transit time is only tl.



### 3.2.5 Benefits

- Ultra fast ring redundancy capability (<1 ms reconfiguration)
- Ultra fast propagation in the ring
- Specific frame control mechanism (store and forward)
- Ring management
- Watchdog relay for supervision

### 3.3 MiCOM H35x functional composition

The figure below shows the MiCOM H35x main functional blocks.

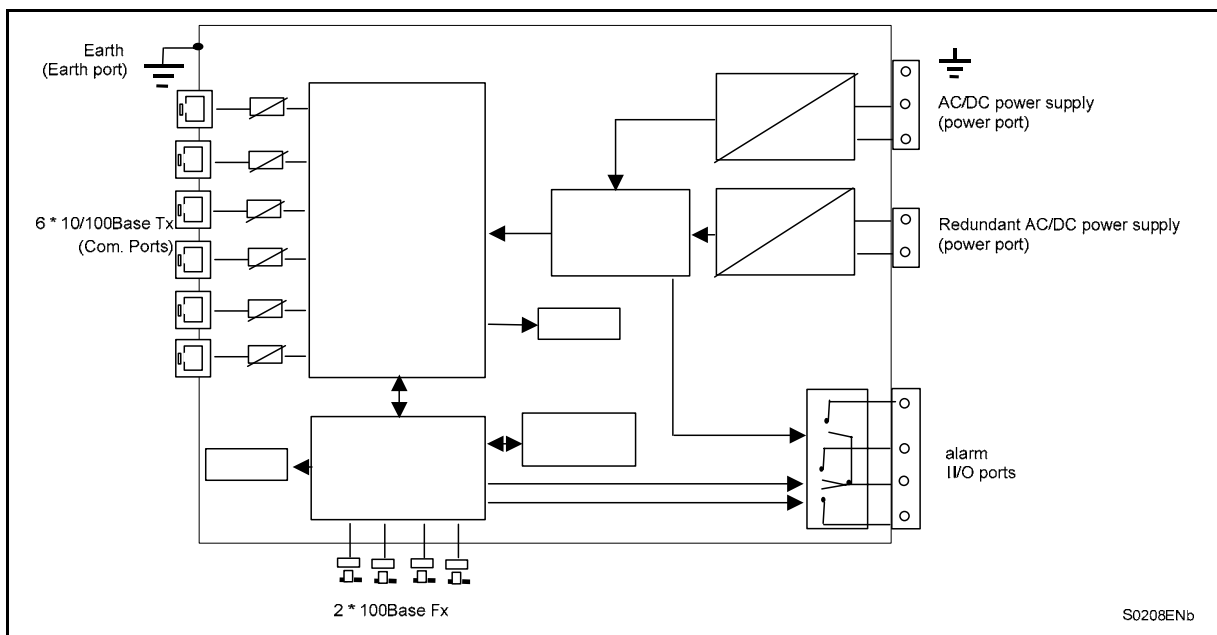

FIGURE 5: MiCOM H352

The central part manages the switching of up to eight Ethernet links. A FLASH Memory stores the switching algorithm and manages the minimum parameters of the Ethernet switching algorithm.

The board has two to six copper connections and two to six optical connections (multi mode or single mode).

LEDs and alarm contacts are defined to check that the product operates correctly.

A redundant power supply provides the device with AC and/or DC voltage; the supported ranges are the most common in electrical plants.

### 3.4 Power management

If a cable is not connected to a port, most of the circuitry for that port is disabled to save power.

### 3.5 Ethernet Port Switching Features

Due to auto-negotiation, MiCOM H35x automatically determines the speed of its transmission layer, 10/100 Mbps, half or full duplex.

#### 3.5.1 10Base Tx and 100Base Tx

The copper ports are half/full duplex and auto-sense the transmission speed. They will auto-negotiate with the connected device to determine the optimal speed. When the connected device is only capable of transmitting at 10 Mbps, the MiCOM H35x follows at 10 Mbps.

#### 3.5.2 100Base Fx

The fiber optic ports are full duplex at 100 Mbps.

**3.6 Ethernet Management**

**3.6.1 Address lookup**

For MiCOM Switches Hxxx & SWx products, a range of MAC addresses are allocated.

By Schneider Electric, the new MAC address range is included on the domain from 00:80:F4:7A:43:00 to 00:80:F4:7A:FF:FF values. The Address Base is allocated with 00:80:F4 value.

The old MAC address range was included on the domain from 00:02:84:03:00:00 to 00:02:84:05:FF:FF values. The Address Base was allocated with 00:02:84 value.

Each Ethernet device inserts its unique "MAC address" into each message it send out. The port on the switch used for given MAC address is automatically learned when a frame is received from that address.

Once an address is learned, the switch will route messages to only the appropriate port.

Up to 1024 MAC addresses can be stored and monitored at any time.

**3.6.2 Auto-negotiation and speed-sensing**

All six RJ45 ports of the MiCOM H352/354 independently support auto-negotiation for speeds in the 10BaseT and 100BaseTx modes. Operation is according to the IEEE 802.3u standard.

**3.6.3 Forwarding**

MiCOM H35x supports the store and forward mechanism. MiCOM H35x forwards messages with known addresses to the appropriate port. Messages with unknown addresses, broadcast messages and multicast messages are forwarded out to all ports except the source port.

**3.6.4 Priority tagging**

802.1p priority is enabled on all ports.

**3.6.5 SNMP v2**

Simple Network Management Protocol is the network protocol developed to manage devices in an IP network. SNMP v2 relies on a Management Information Base (MIB) that contains information about parameters to supervise. A MIB's format is a tree structure, with each node identified by a numerical Object IDentifier (OID). Each OID identifies a variable that can be read or set via SNMP with the appropriate software. The information in MIBs is standardized.

**3.6.5.1 H35x MIB Structure**

The SNMP MIB consists of distinct OIDs, each of which refers to a defined collection of specific information used to manage devices on the Schneider Electric ring. The Schneider Electric MIB uses three types of OID.

**System:**

Address										Name	
0										Ccitt	
	1									ISO	
		3								Org	
			6							DOD	
				1						Internet	
					2					mgmt	
						1				Mib-2	
							1			sys	
								1		sysDescr	Schneider Electric Switch
									3	sysUpTime	xday yh:zm:zzs:yyms
									4	sysName	

FIGURE 6: H35X MIB STRUCTURE

**RMON:**

Address											Name	
0												Ccitt
	1											ISO
		3										Org
			6									DOD
				1								Internet
					2							mgmt
						1						Mib-2
							16					Rmon
								1				stat
									1			etherstat
									1	9		Port number (*)
										10	etherStatsIndexetherStatsUndersizePkts	
										12	etherStatsIndexetherStatsOversizePkts	
										13	etherStatsIndexetherStatsJabbers	
										14	etherStatsIndexetherStatsCollisions	
										15	etherStatsIndexetherStatsPkts64Octets	
										16	etherStatsIndexetherStatsPkts65to127Octets	
										17	etherStatsIndexetherStatsPkts128to255Octets	
										18	etherStatsIndexetherStatsPkts256to511Octets	
										19	etherStatsIndex etherStatsPkts512to1023Octets	

\*Port number: 1 to 6 for the RJ45, port 7 management, port 8 ring

### 3.6.5.2 SNMP Software

Various "SNMP Client software" tools can be used with the MiCOM H35x range. Schneider Electric does not provide such tools.

Any MIB Browser Software performing the basic SNMP operations (such as GET, GETNEXT, GETRESPONSE...) can work with the MiCOM H range.

## 4. TECHNICAL DATA

### 4.1 MiCOM H35x Range

Ports	10/100BaseTx Copper	100 BaseFx Multimode (ring)	100 BaseFx Single Mode (ring)
MiCOM H352-V2	6	2 (ST)	-
MiCOM H354-V2	6	-	2 (SC)

### 4.2 CONFORMITY

(As per Article 10 of EC Directive 2006/95/EC).

The products designated "MiCOM H352-V2", "MiCOM H354-V2" have been designed and manufactured in compliance with standard IEC 60255-27:2005 and are compliant with European Commission Low Voltage Directive 2006/95/EC.

### 4.3 Ethernet Port Characteristics

#### 4.3.1 10/100BaseTx Port

Connector type	Shielded RJ45 jack
Twisted pair cable	Cat 5
Max. cable length with Cat 5	100 m

FIGURE 7: 10/100BASETX PORT

#### 4.3.2 100BaseFx Multimode Port (H352)

Fiber port connector	ST
Optimal fiber cable	62.5/125 $\mu\text{m}$ or 50/125 $\mu\text{m}$
Center wavelength	1310 nm
TX output power	-19 dBm
RX input sensitivity	-31 dBm
Maximum distance	2000 m

FIGURE 8: 100BASEFX MULTIMODE PORT (H352)

#### 4.3.3 100BaseFx Single Mode Port (H354)

Fiber port connector	SC
Optimal fiber cable	9/125 or 10/125 $\mu\text{m}$
Center wavelength	1310 nm
TX output power	-15 dBm
RX input sensitivity	-34 dBm
Maximum distance	20,000 m

FIGURE 9: 100BASEFX SINGLE MODE PORT (H354)

#### 4.4 General Characteristics

##### 4.4.1 Mechanical

Dimensions	W x H x D = 235 mm x 170 mm x 50 mm
Weight	1.3 Kg
Mounting	DIN Rail EN50022

##### 4.4.2 Auxiliary Power Supply

Supply voltage range	24 to 48 Vdc 110 to 220 Vdc & 110 to 230 Vac
Power consumption	10 W

##### 4.4.3 Auxiliary Fault Relay

Connector	3 NC contact potential free
DC voltage	250 Vdc
Continuous current	5 A
Switching current	100 A / 30 ms
Power breaking with time constant	10 W under 48 Vdc with $\tau = 20$ ms

##### 4.4.4 Ethernet Management

Standards	IEEE802.3, 802.3u, 802.3x, 802.1p
Forwarding mode	Store and forward
Memory bandwidth	2 Gbps
MAC Address	1K
Address learning	Automatic
Broadcast storm protection	Limited to 5%
Illegal frame	Dropped per 802.3
Late collision	Dropped after 512 bit times
Latency	4 $\mu$ s measured at 75% load between two ports at 100 Mbs

## 4.5 Environmental Characteristics

### 4.5.1 Electrical

Type Test Name	Conditions	Type Test Standard
Voltage tolerance	DC -20 to + 20% AC -20 to + 20%	IEC 60255-6
DC Supply interruption	0.88 V <sub>min</sub> for 2 to 100 ms	IEC 60255-11
AC Supply interruption	0.4 V <sub>n</sub> for 10 to 1000 ms	IEC 61000-4-11
AC Supply Main frequency fluctuation	44 to 66 Hz	IEC 60255-6
DC Supply Overvoltage	1.32 V <sub>n</sub> 100 ms	IEC 60255-6
DC Supply Inrush current		HR46-R-01-4 DICOT
DC Supply Ripple	15% U <sub>n</sub> 100 Hz	IEC61000-4-17
Overcurrent protection	Non-changeable fuse	

### 4.5.2 Isolation

Type Test Name	Conditions	Type Test Standard
Dielectric strength Aux. Power RJ45 ports	3 kV <sub>dc</sub> for 1 minute 1.5 kV <sub>dc</sub> for 1 minute	IEC 60255-5
Insulation resistance	100 MΩ at 500 V	IEC 60255-5
Impulse voltage	5 kV common mode 1 kV differential mode	IEC 60255-5

### 4.5.3 Climatic

Type Test Name	Conditions	Type Test Standard
Extended dry heat – Operating	Test Ca: +55 °C / 20d, +70 °C / 24h	IEC 60068-2-2 / 1993
Cold Test - Operating	Test Ab: -40 °C / 96h	IEC 60068-2-1 / 1993
Cold Test - Storage	Test Ad: -40 °C / 96h Powered On at -25 °C (for information) Powered On at -40 °C (for information)	IEC60068-2-1 / 1993
Dry Heat Test – Operating	+70 °C / 24h	IEC 60068-2-2 / 1993
Dry Heat Test – Storage	Test Bd: +70 °C / 96h Powered On at +70 °C	IEC 60068-2-1 / 1993
Humid heat Test - Operating	40 °C, 93% RH, 10 day	NFC 20-703 / 1986
Enclosure Protection	IP = 20	IEC 60529

## 4.5.4 Electromagnetic Compatibility

Type Test Name	Conditions	Type Test Standard
Electrostatic discharge	Class 4: 8 kV contact / 15 kV air	IEC 60255-22-2 IEC 61000-4-2 /2001
Radio frequency impulse	Class 3: 10 V/m – 80 to 1000 MHz & spot tests 35 V/m – 25 to 1000 MHz	IEC 60255-22-3 IEC 61000-4-3 / 2002 IEEE C37.90.2
Fast transient burst	Class 4: 4 kV – 2.5 kHz (CM)	IEC 60255-22-4 IEC 61000-4-4 / 2001 IEEE C37.90.1
Surge Immunity	Class 4: 4 kV (CM) – 2 kV (DM)	IEC 61000-4-5 / 2001
High frequency conducted immunity	Class 3: 10 V, 0.15 – 80 MHz	IEC 61000-4-6 / 2001
Power Frequency Magnetic Field Immunity	Class 5: 100 A/m 1000 A/m	IEC 61000-4-8 / 2001
Pulse Magnetic Field Immunity	Class 5: 1000 A/m	IEC 61000-4-9 / 2001
Damped oscillatory magnetic field immunity	Class 5: 100 kHz & 1 MHz – 100 A/m	IEC 61000-4-10 /2000
Oscillatory waves immunity	Class 4: 2.5 kV (CM) – 1 kV (DM)	IEC 61000-4-12 /2001
Conducted emission	Gr. I, class A and B: from 0.15 to 30 MHz	EN 55022 / 2003

## 4.5.5 Mechanical

Type Test Name	Conditions	Type Test Standard
Free Fall Test	2 falls of 5 cm (not powered)	IEC 60068-2-31
Free Fall Packaging Test	25 falls of 50 cm (Packaging)	IEC 60068-2-32
Vibration Response – Powered On	Class 2: Acceleration: 1g from 10 (1) to 150 Hz	IEC 60255-21-1
Vibration Response – Not Powered On	Class 2: Acceleration: 2g from 10 (1) to 500 Hz	IEC 60255-21-1
Vibration Endurance – Not Powered On	Class 2: Acceleration: 1g from 10 (1) to 500 Hz	IEC 80068-2-6
Shocks – Not Powered On	Class 1: 15g, 11 ms	IEC 60255-21-2
Shocks – Powered On	Class 2: 10g, 11 ms	IEC 60255-21-2
Bump Test – Not Powered On	Class 1: 10g, 16 ms, 2000/axis	IEC 60255-21-2
Seismic Test – Powered On	Class 2: Acceleration: 2g Displacement: 7.5 mm on H axis Acceleration: 1g Displacement: 3.5 mm on V axis	IEC 60255-21-3

### 5. HUMAN MACHINE INTERFACE (HMI)

Several LEDs are used to indicate the status of the MiCOM H35x ports and links.

#### 5.1 H352-V2 HMI

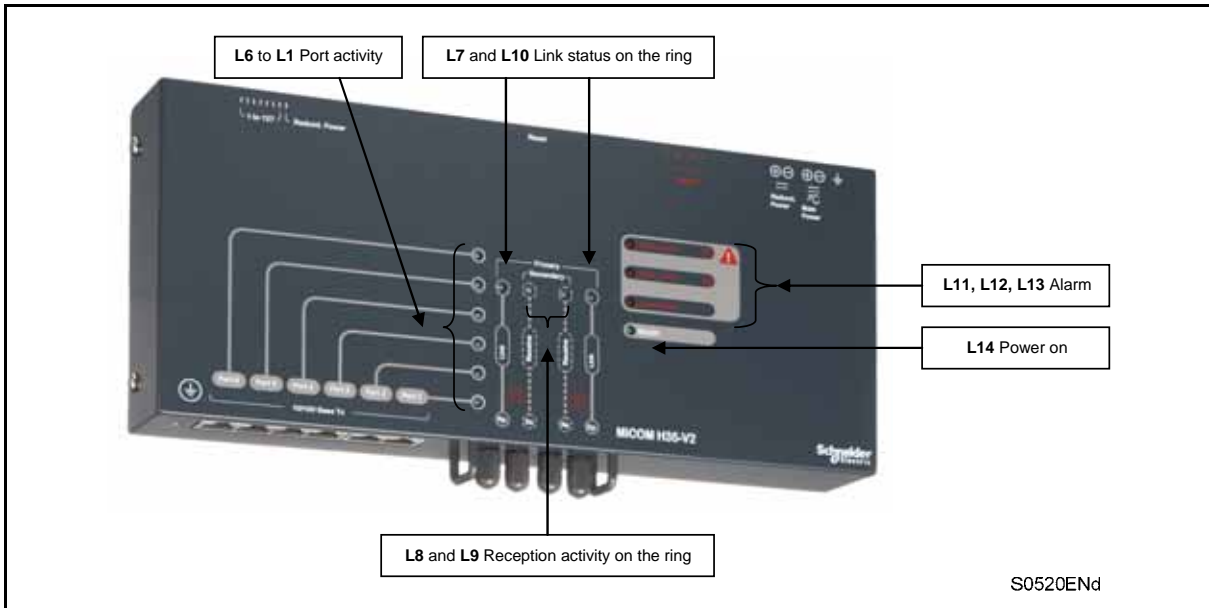

FIGURE 10: H352-V2 HMI

#### 5.2 H356/H358 HMI

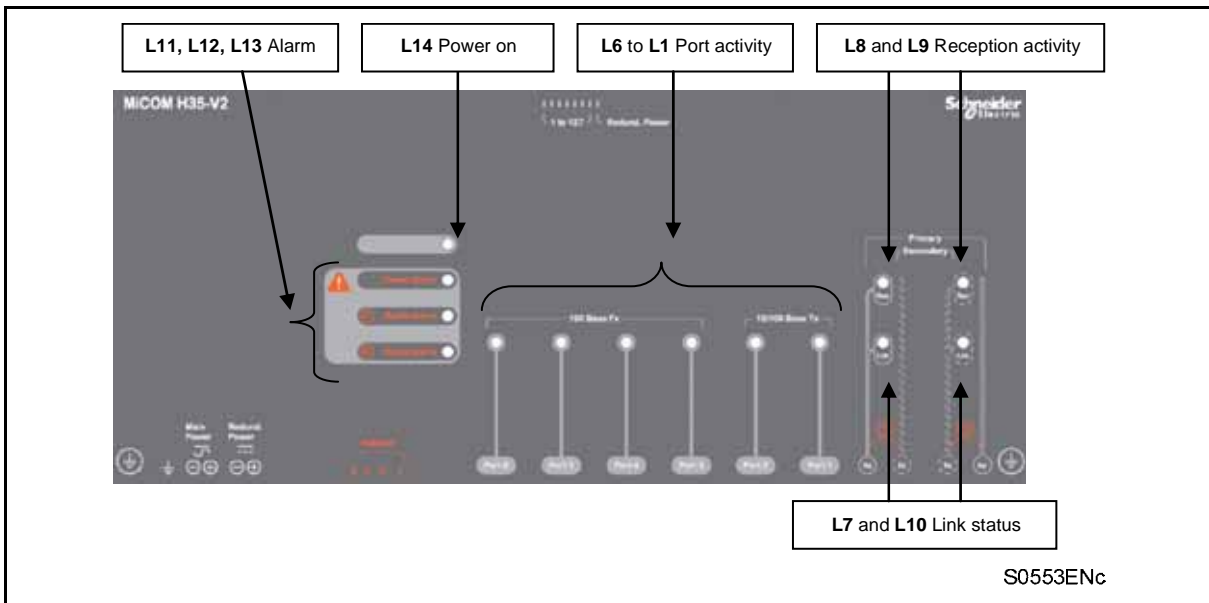



FIGURE 11: H356/H358 HMI



### 5.3 H35x LEDs

The table below indicates the function of each LED:

LED	N°	Color	Description	Comments
Power	L14	GREEN OFF	Power is Applied Power is OFF	
Alarm power supply	L13	RED OFF	Power supply fault No default	
Alarm Link B	L12	RED OFF	Dual Homing Rs-Ep Link B No default Rs-Ep Link B	
Alarm Link A	L11	RED OFF	Dual Homing Rs-Ep Link A No default Rs-Ep Link A	
Secondary Ring	L10	GREEN OFF	Optical link- OK No link	in normal conditions both LED L9 and L10 are green
Secondary Ring	L9	GREEN OFF	Reception of data – OK	
Primary Ring	L8	GREEN OFF	Reception of data -OK	in normal conditions both LED L7 and L8 are green
Primary Ring	L7	GREEN OFF	Optical link - OK No link	
Ports 1 to 6	L6 to L1	GREEN GREEN flashing OFF	Connected without activity Activity No connection	

At power up, the MiCOM H3xx goes through a series of self-tests. The 6 LEDs will flash for a few seconds.

### 6. INSTALLATION

The MiCOM H35x can be easily mounted on a standard DIN Rail.

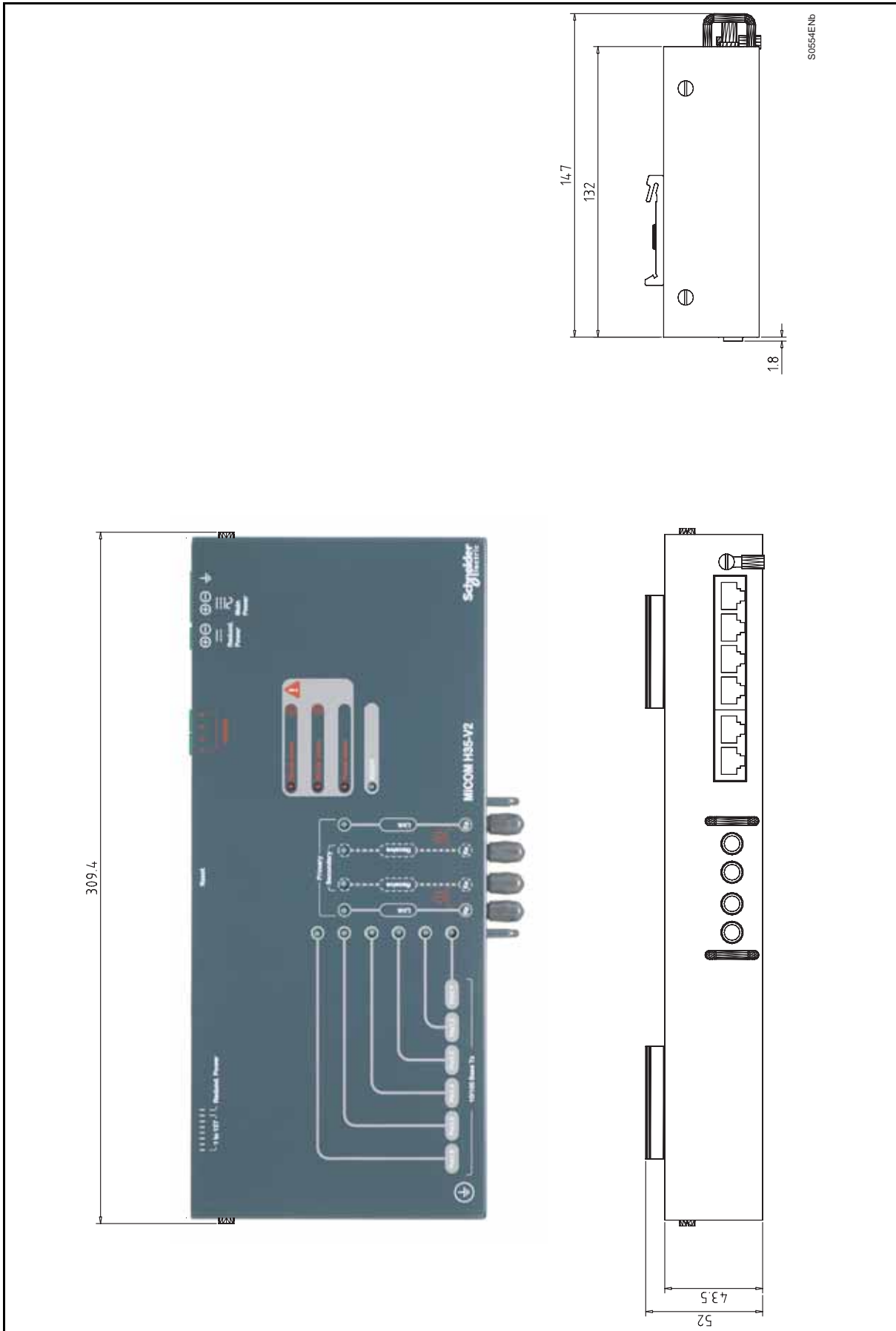

## 7. CONNECTION

MiCOM H3xx must be connected to the earth according to product safety standard EN60255-27:2005 clause 5.1.5, using the protective conductor (earth) terminal located on the bottom of the case.

### 7.1 Connection of the protective conductor (earth)

The MiCOM H3xx must be earthed, for safety reasons, by connecting the protective conductor (earth) to the M4 threaded stud which is marked with the symbol shown.

**WARNING – TO PRESERVE THE EQUIPMENT'S SAFETY FEATURES THE PROTECTIVE CONDUCTOR (EARTH) MUST NOT BE DISTURBED WHEN CONNECTING OR DISCONNECTING FUNCTIONAL EARTH CONDUCTORS, SUCH AS CABLE SCREENS, TO THE PCT STUD.**



**THE PROTECTIVE CONDUCTOR MUST BE CONNECTED FIRST, IN SUCH A WAY THAT IT IS UNLIKELY TO BE LOOSENEED OR REMOVED DURING INSTALLATION, COMMISSIONING OR MAINTENANCE. THIS MAY BE ACHIEVED BY USE OF AN ADDITIONAL LOCKING NUT.**

The protective conductor (earth) must be as short as possible, with low resistance and inductance. The best electrical conductivity must be maintained at all times, particularly the contact resistance of the plated steel stud surface. The resistance between the MiCOM H3xx protective conductor (earth) terminal (PCT) and the protective earth conductor must be less than 10 mΩ at 12 Volt, 100 Hz.

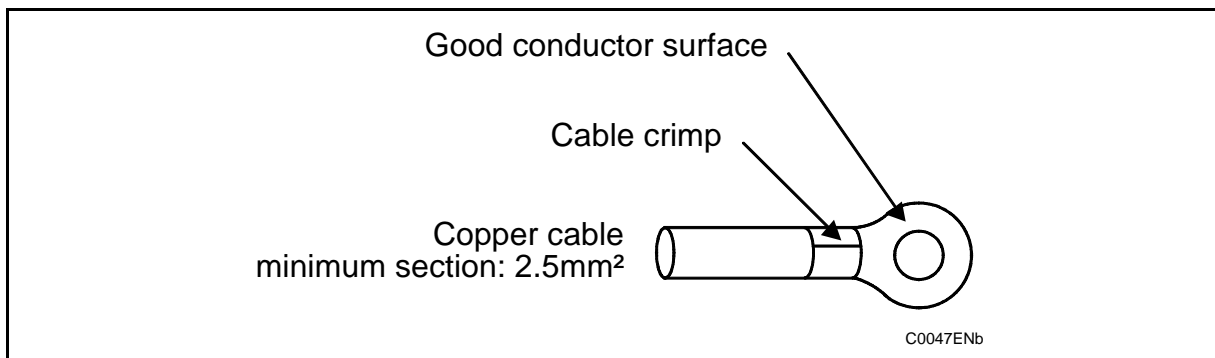

FIGURE 12: EARTHING CABLE EXAMPLE

### 7.2 Cable fitting

Use of the following cables is recommended:

- Screened multi-strand cable must be used for digital input-output signals. For cables within the cubicle, the cable screen can be connected to the earth at both ends of the cable. If the cable is taken beyond the system cubicle, the cable screen should be earthed at one end only to prevent current flowing in the screen due to any difference in ground potential.
- A screened twisted pair must be used for analog input-output signals. The screen is connected to the earth at the end on the Bay Module side.
- One or two screened twisted pairs must be used for lower communication signals. The screen is connected to the earth by two cable ends.

It is recommended to group the cables and link them together to the nearest earth plane, or to an element of the earth wire-mesh.

### 7.3 Power supply wiring

Connection to the power supply (main and/or redundant) requires 4 mm<sup>2</sup> screw type terminals. The diagram is identical for AC and DC power. Both power supplies are isolated from each other.

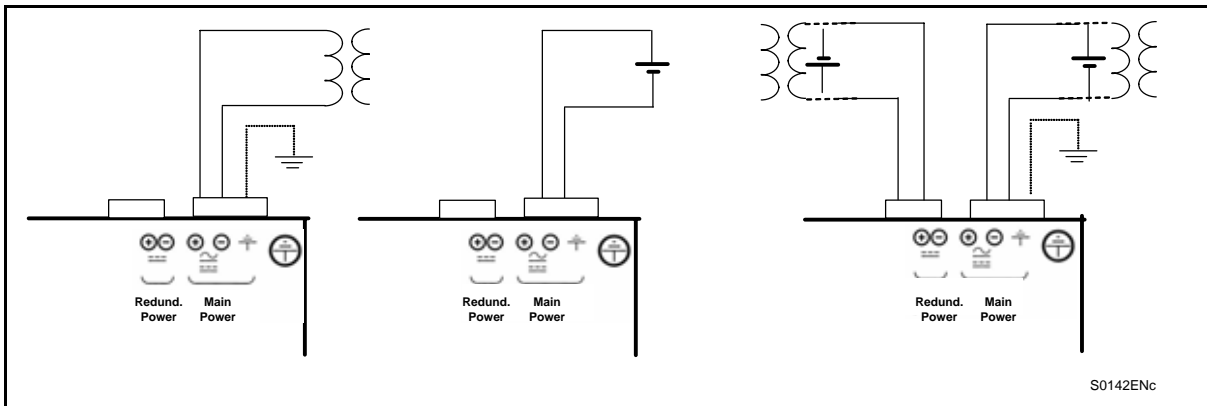

FIGURE 13: POWER SUPPLY WIRING

#### MANDATORY SAFETY WIRING RECOMMENDATIONS:

- The power supply earth cable must be screwed onto the connector (3 points). (as shown on Figure 15 BIS).

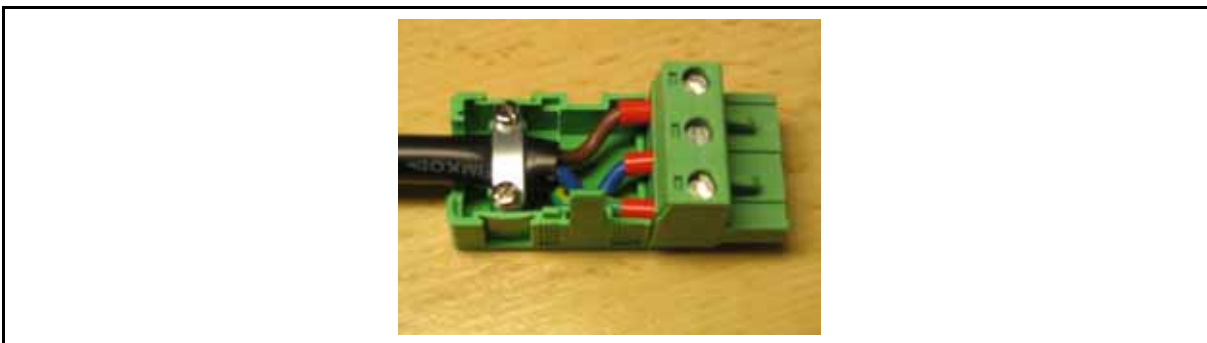

FIGURE 15 BIS: POWER SUPPLY WIRING

- The full plastic cover must be installed on the power supply connector. (as shown on Figure 15 TER).
- The plastic cover must be attached with the cable tie supplied. (with the white cable tie around the connector, as shown on Figure 15 TER).

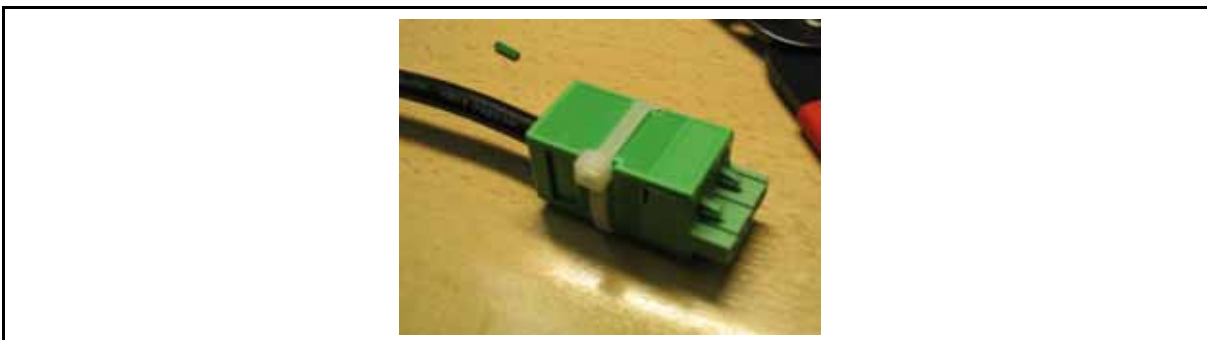

FIGURE 15 TER: POWER SUPPLY COVER AND CABLE TIE

**7.4 Fail-safe contacts**

The screw type terminals are 4 mm<sup>2</sup>.

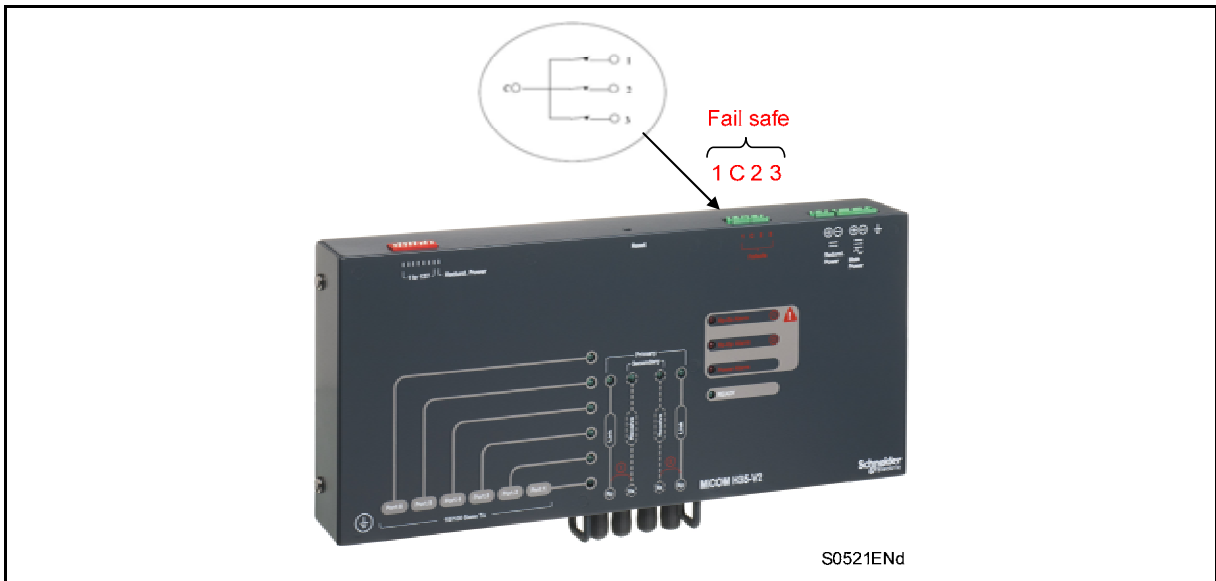

FIGURE 14: FAIL-SAFE CONTACTS WIRING

Pin No.	Contact meaning
1	Power supply Alarm (see section 9.2 for configuration)
C	Common Vdc
2	Ep/Rs optical link broken
3	Es/Rp optical link broken

A closed contact means an alarm or a fault.

**MANDATORY SAFETY WIRING RECOMMENDATIONS:**

- The full plastic cover must be installed on the “Fail-Safe” connector. (as shown on Figure 16 BIS).
- The plastic cover must be attached with the cable tie supplied. (with the white cable tie around the connector, as shown on Figure 16 BIS).



FIGURE 16 BIS: FAIL-SAFE CONTACTS CONNECTOR

## 7.5 Ethernet Connection

The Ethernet-based communication available in the MiCOM H35x uses either optical fiber media (ST/SC connector) or 4 twisted pair cable.

If the equipment is located at a long distance (>100 m for RJ45) from the communication equipment or multiplexer, or if the cables run through a noisy area, then optical communication should be used to interconnect the IEDs and the communication equipment.

### 7.5.1 Ethernet cable type

Only the cable insulated category 5 (FTP: Foil Twisted Pair) or insulated (STP – Shielded Twisted Pair) with RJ45 connectors must be used.

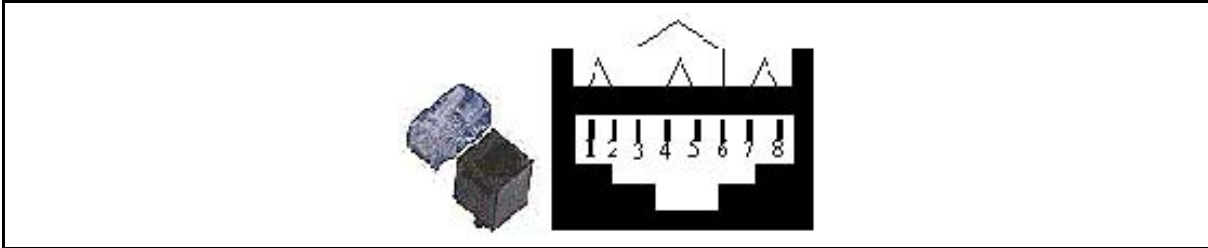

FIGURE 15: RJ45 CONNECTOR

The standard is:

- 1 = white / orange
- 2 = orange
- 3 = white / green
- 4 = blue (not used)
- 5 = white / blue (not used)
- 6 = green
- 7 = white / brown (not used)
- 8 = brown (not used)

Looking at the RJ45 connector head on, flat side on bottom and side tab on top, then pin 1 is on the left and pin 8 on the right.

The MiCOM H35x supports star or tree network topology.

The maximum authorized cable length for 10/100BaseTx without using a repeater is 100 meters.

### 7.5.2 Ethernet optical fiber

The optical fiber cables are connected to the corresponding optical fiber elements.

The H352-V2 P/N 2071684 A01 (**multimode** fiber) has a type **ST** connector.



FIGURE 16: ETHERNET OPTICAL FIBER – ST

The H354-V2 P/N 2071684 A02 (**single mode** fiber) has a type **SC** connector.



FIGURE 17: ETHERNET OPTICAL FIBER – SC

## 8. SETTINGS

### 8.1 Dip switch description

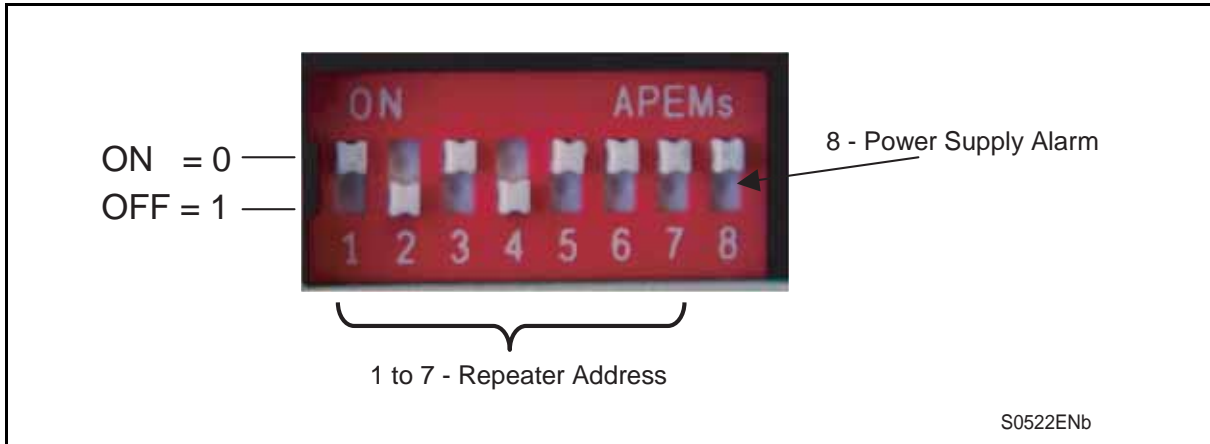

FIGURE 18: DIP SWITCHES

Name	Function
Repeater address	Define the repeater address on the ring
Power supply alarm	Generate alarm if there is no redundant power supply

### 8.2 Address of the repeater

Each repeater in the ring has a specific address. Each address must be unique and included between 1 and 127.

#### 8.2.1 Configuring the address

The address is equal to the sum of the « OFF bits ».

At the beginning address = 0

If 1 = OFF	address = address + 1	If 1 = ON	address = address + 0
If 2 = OFF	address = address + 2	If 2 = ON	address = address + 0
If 3 = OFF	address = address + 4	If 3 = ON	address = address + 0
If 4 = OFF	address = address + 8	If 4 = ON	address = address + 0
If 5 = OFF	address = address + 16	If 5 = ON	address = address + 0
If 6 = OFF	address = address + 32	If 6 = ON	address = address + 0
If 7 = OFF	address = address + 64	If 7 = ON	address = address + 0

#### 8.2.2 Example: defining address "10"

J7-1 = ON	address = address + 0
J7-2 = OFF	address = address + 2
J7-3 = ON	address = address + 0
J7-4 = OFF	address = address + 8
J7-5 = ON	address = address + 0
J7-6 = ON	address = address + 0
J7-7 = ON	address = address + 0

**Address = 10**



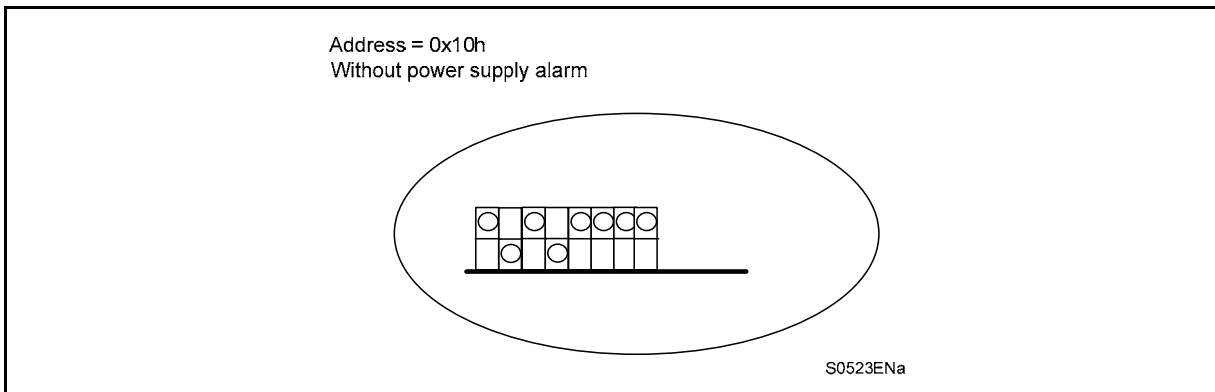

FIGURE 19: DIP SWITCHES EXAMPLE

### 8.3 IP Address of the repeater

The repeater IP address is established in the following way:

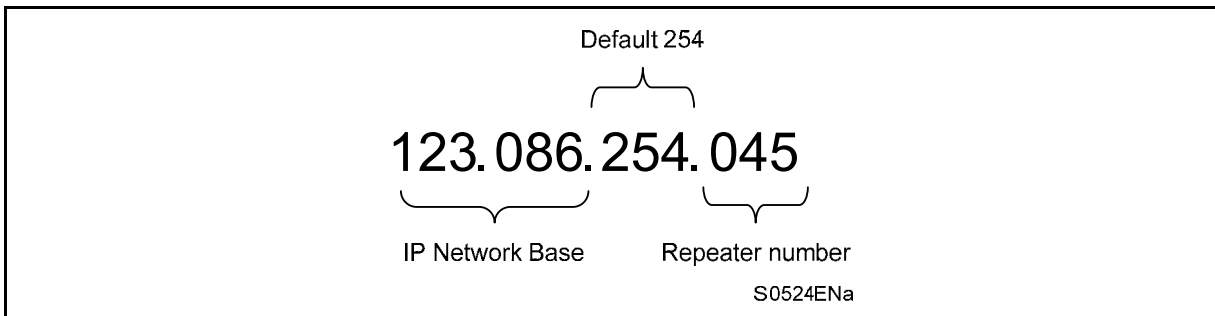

FIGURE 20: IP ADDRESS

There are two tools to configure the IP address, the Schneider Electric\_Switch\_manager Software or the Schneider Electric\_Switch\_Ip\_Repeater Software.

**Note:** It is important to note that the Schneider Electric\_Switch\_manager Software forces the third IP byte field to take the value “254”.

### 8.4 Power supply alarm

The power supply alarm DIP switch position indicates the role of the Fail contact output:

When positioned to “ON”, “Fail-safe” contact 1 indicates the redundant power supply status.

When positioned to “OFF”, “Fail-safe” contact 1 is unused.

### 8.5 Label

A rectangular label on top of MiCOM H35x behind Auxiliary Power input J1 J2, gives two major indications:

- Type: H35C2 : Code C for nominal power supply (110 - 220 VDC or VAC)  
Code B for nominal power supply (24 - 48 VDC or VAC)
- Multimode or Single mode optical fiber supported.

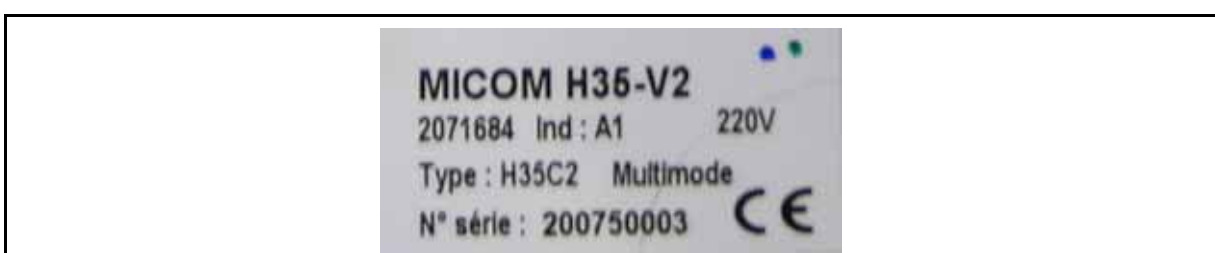

FIGURE 21: MiCOM H35x LABEL

## 9. MAINTENANCE

### 9.1 Scope

This chapter describes the maintenance procedure for the MiCOM H3xx.

### 9.2 Recommendation before maintenance operations



**BEFORE CARRYING OUT ANY WORK ON THE EQUIPMENT, THE USER SHOULD BE FAMILIAR WITH THE CONTENTS OF THE SAFETY AND TECHNICAL DATA CHAPTERS (SCHNEIDER ELECTRIC SAFETY GUIDE: SFTY/4L M/C11 OR LATER ISSUE) AND THE RATINGS ON THE EQUIPMENT'S RATING LABEL.**

**READING THE “SAFETY AND HANDLING” CHAPTER OF THIS DOCUMENT IS MANDATORY BEFORE ANY MAINTENANCE OPERATION.**



- All power supply connectors must be disconnected from the device prior to any maintenance operation.
- When the MiCOM H3xx device is connected to dual external electrical sources, both power supply connectors (main and redundant) should be disconnected prior to any maintenance operation.



FIGURE 22: POWER SUPPLY CONNECTOR

### 9.3 Maintenance period

Schneider Electric products should be monitored periodically after their installation. Deterioration may occur over time. Because of the electrical and heavy-interference environment, the MiCOM Hxxx should be checked at regular intervals to confirm that it is operating correctly.

The Schneider Electric MiCOM Hxxx has been designed for a life cycle of over 15 years.

MiCOM H3xx is self-supervising and therefore requires less maintenance than previous products. Most problems will lead to an alarm so that fast and appropriate action can be taken. However, some periodic checks should be done to ensure that the external wiring is in proper condition.

If the customer's organization has a Preventive Maintenance Policy, then the recommended product checks should be included in the regular program.

## 9.4 Diagnosis facilities

When a maintenance action is planned, the operator should prepare, act and report.

The minimum preparation is to obtain the commissioning Record Sheet of installed device in order to check the product configuration and its history. The user should also apply personal experience in addition to this manual.

On a first level, the product provides several methods to identify the context of the fault. The main ones are:

- Power LEDs
- Fail-Safe alarm indication

The LEDs and fail-safe indications are described in the chapter Human Machine Interface.

## 9.5 Method of repair

IN CASE OF DEVICE FAILURE, THE PREFERRED METHOD IS TO REPLACE THE COMPLETE MiCOM H3XX, AS THIS ENSURES THAT THE INTERNAL CIRCUITRY IS PROTECTED AGAINST ELECTROSTATIC DISCHARGE AND PHYSICAL DAMAGE AT ALL TIMES.

### 9.5.1 Replacing the MiCOM H3xx

The case and connectors have been designed for ease of use, so removing the MiCOM H3xx is very simple.

#### 9.5.1.1 Uninstalling the MiCOM H3xx

Before any disconnection, check that the labels correctly define the connectors and match the description you have.

Otherwise, note the dip-switch positions in order to prepare the new MiCOM H3xx installation.

1. Disconnect both power supply connectors (when wired):
2. Disconnect the MiCOM H3xx Fail-Safe Alarm Connector:
3. Disconnect the Ethernet RJ45 connectors
4. Disconnect the Ethernet optical connectors
5. Disconnect the protective earth connection
6. Withdraw the MiCOM H3xx from the DIN rail carefully, paying attention to its weight.

#### 9.5.1.2 Installing a fresh MiCOM H3xx

To reinstall the repaired or the new MiCOM H3xx:

- Set the new MiCOM H3xx IP address (dip switches)
- Follow the above procedure in reverse.

## 10. APPLICATIONS

### 10.1 Fiber Optic budget calculations

Optical power is expressed in Watts. However, the common unit of power measurement is the dBm, defined by the following equation:  $\text{Power (dBm)} = 10 \log \text{Power (mW)} / 1 \text{ mW}$ .

The fiber optic budget is the difference between the power emitted into the fiber and the sensitivity (minimum amount of power required) of the receiver connected through the fiber optic cable.

$$\text{Link Power Budget} = \text{Transmitter Power (dBm)} - \text{Receiver Sensitivity (dBm)}$$

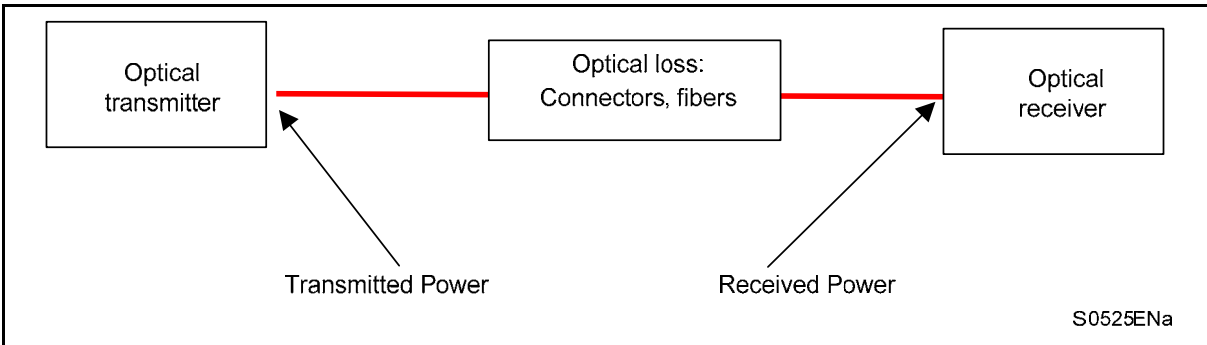

FIGURE 23: FIBER BUDGET

Example:

The following example shows the calculation of the maximum range for various types of fiber.

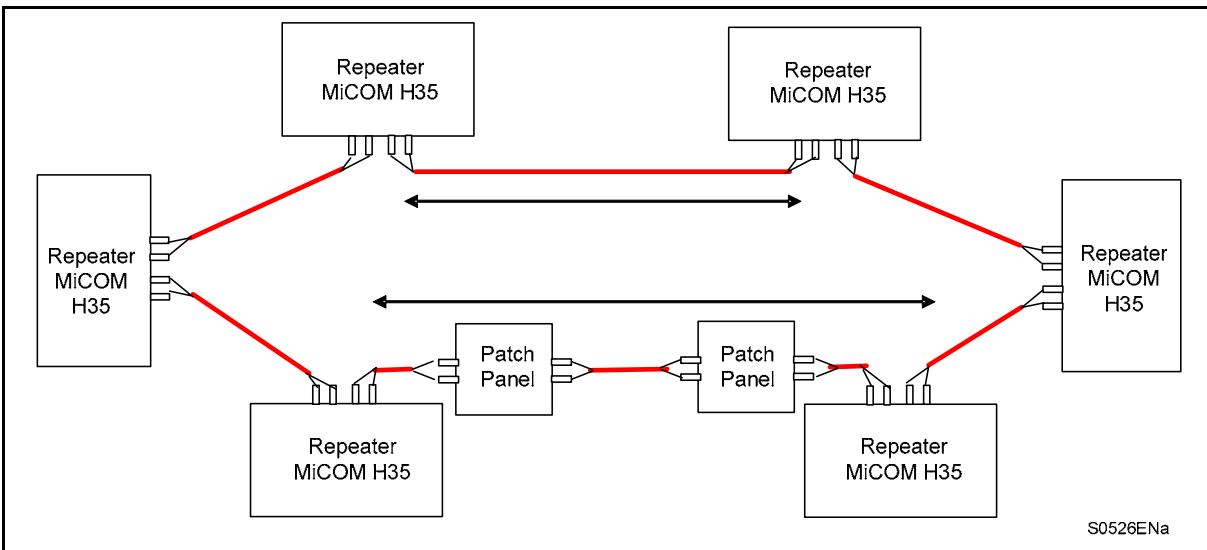

FIGURE 24: FIBER BUDGET EXAMPLE

Fiber type	Multimode	Single mode
	62.5/125 micron	9/125 micron
Power coupled into fiber	-19 dBm	-15 dBm
Sensitivity	-31 dBm	-34 dBm
Link budget	12 dB	19 dB

## 10.1.1 Example 1: between repeaters

Link budget	12 dB	19 dB
Connector loss (2)	0.8 dB	0.8 dB
Safety Margin	4 dB	4 dB
Allowed link attenuation	6.4 dB	13.4 dB
Typical cable attenuation	1 dB/km	0.4 dB/km
Maximum range	6.4 km	33 km

## 10.1.2 Example 2: between repeaters with patch panel

Link budget	12 dB	19 dB
Connector loss (6)	0.8 dB	0.8 dB
Patch loss (2)	2 dB	1 dB
Safety Margin	4 dB	4 dB
Allowed link attenuation	-0.8 dB	8.2 dB
Typical cable attenuation	1 dB/km	0.4 dB/km
Maximum range	0	20 km

The values given above are only approximate ones. Always use cable and connector losses as specified by the manufacturer.

## 11. GLOSSARY

<b>100Base Fx</b>	The fiber optic ports are full/half duplex at 100 Mbps only.
<b>10Base Tx and 100Base TX</b>	The copper ports are full/half duplex and auto-sense the transmission speed. They will auto-negotiate with the connected device to determine the optimal speed. When the connected device is only capable of transmitting at 10 Mbps, the MiCOM H35x follows the 10 Mbps.
<b>Cat. 5</b>	Category 5 unshielded twisted pair (UTP) cabling. An Ethernet network operating at 10 Mbits/second (10BASE-T) will often tolerate low quality cables, but at 100 Mbits/second (10BASE-Tx) the cable must be rated as Category 5, or Cat 5 or Cat V, by the Electronic Industry Association (EIA). This rating is printed on the cable jacket. Cat 5 cable contains eight conductors, arranged in four twisted pairs, and terminated with an RJ45 type connector. In addition, there are restrictions on maximum cable length for both 10 and 100 Mbits/second networks.
<b>Fast Ethernet</b>	An Ethernet system that is designed to operate at 100 Mbps.
<b>Half-duplex</b>	A system that allows packets to be transmitted and received, but not at the same time. Contrast with full-duplex.
<b>MAC address</b>	The Media Access Control address is a unique 48-bit hardware address assigned to every network interface card. Usually written in the form 01:23:45:67:89:ab.
<b>MIB</b>	See "Management Information Base" in section 4.6.5.1.
<b>PHY</b>	The OSI Physical Layer: The physical layer provides for transmission of cells over a physical medium.
<b>Power management</b>	If there is no cable on a port, most of the circuitry for that port is disabled to save power.
<b>RMON</b>	Short for remote monitoring, a network management protocol that allows network information to be gathered at a single workstation. Whereas SNMP gathers network data from a single type of Management Information Base (MIB), RMON 1 defines nine additional MIBs that provide a much richer set of data about network usage. For RMON to work, network devices, such as hubs and switches, must be designed to support it. The newest version of RMON, RMON 2, provides data about traffic at the network layer in addition to the physical layer. This allows administrators to analyze traffic by protocol.
<b>Simple Network Management Protocol</b>	SNMP is the protocol governing network management and the monitoring of network devices and their functions.





## Customer Care Centre

<http://www.schneider-electric.com/CCC>

### **Schneider Electric**

35 rue Joseph Monier  
92506 Rueil-Malmaison  
FRANCE

Phone: +33 (0) 1 41 29 70 00

Fax: +33 (0) 1 41 29 71 00

[www.schneider-electric.com](http://www.schneider-electric.com)

**Publication: H35x/EN GL/C24**

Publishing: Schneider Electric

06/2012