

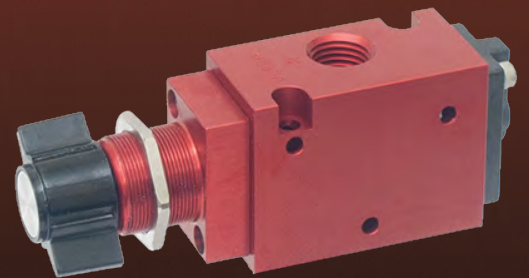

Bulletin C  
2020  
Revised August, 2022

# C-SERIES

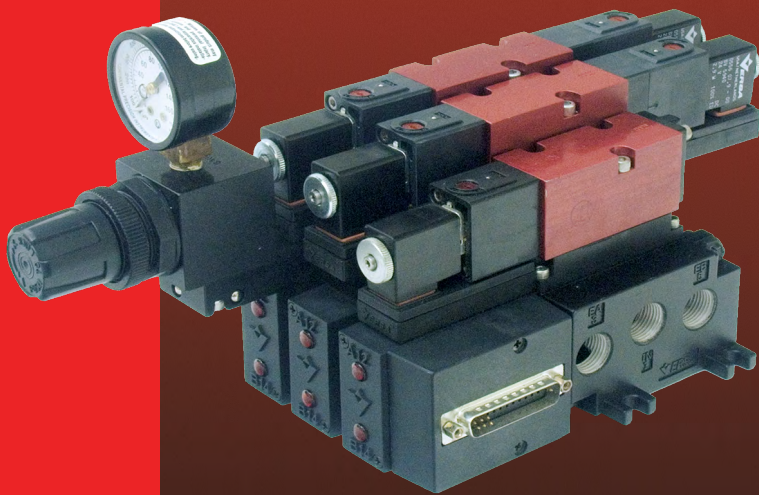

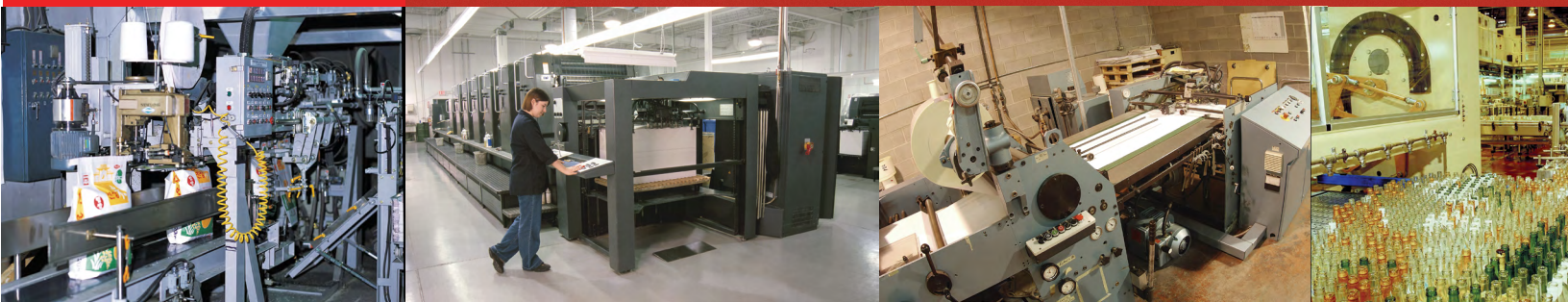

# C Series

## Valves

Selector chart, Valves.....	Page 5
Solenoid Operated (side ported and manifold mounted).....	Page 6
Pilot Operated.....	Page 6-7
Palm button.....	Page 7-8
Rotary.....	Page 8-9
Lever.....	Page 9-10

## Electrical

General Purpose Solenoids.....	Page 11
Hazardous Location Solenoids.....	Page 12-13
Recommended Hazardous Location Solenoid Option Packages.....	Page 14

## Manifolds

Manifold Selector (Plug-In).....	Page 15
Manifold Selector (Rack Mounted).....	Page 19
Manifold Accessories (Plug-In).....	Page 16-18
Manifold Accessories (Rack Mounted).....	Page 19

Repair kits.....	Page 4
------------------	--------

Specifications.....	Page 4
---------------------	--------

Dimensions.....	Page 20
-----------------	---------

## GENERAL DESCRIPTION

Versa's C-Series, C5, C7 & C9, valves are multi-purpose three and four-way, 2 and 3 position, solenoid/pilot, pilot and manually operated pneumatic valves consisting of two body types; side ported and manifold mounted. All the C-Series solenoid valves utilize a high performance solenoid pilot design. This design takes advantage of the available media pressure/force to shift valve assuring positive shifting. A low power solenoid controls the pilot signal which provides the positive force for shifting the valve spool. Solenoid/pilot supply can be either Inpilot or Expilot.

Double solenoid/pilot 2 position models feature detented offset positions. Double solenoid/pilot 3 position models feature a spring return to the unactuated center position with all ports blocked or exhaust ports open in the center position or cylinder ports open to inlet.

A balanced, packed spool is the flow controlling element of each valve. The balanced spool allows the force necessary to shift the valve to remain independent of the pressure of the medium being controlled. The use of elastomer sealing provides bubble tight operation thus enabling positive positioning of 3 position devices and thrift of operation due to no waste of leaking air.

## Features: Valve

**Anodized Aluminum And Stainless Steel Construction**  
All wetted parts resist damage due to corrosion.

**Bubble Tight service**  
Provides leak tight sealing reducing cost due to wasted air and positive positioning of actuated device when utilizing 3-position valves.

**Life Cycle**  
Rated for 20 million bubble tight cycles in lubricated service (10 million in non-lubricated service).

**Epoxy molded coils**  
For moisture resistance & heat dissipation.

**Air-Assisted Spring Return**  
Air boosts spring for positive valve return.

**Balanced Spool**  
Forces required to actuate the valve are unaffected by the controlled pressure.

**Wafer Sealing**  
Wafer type elastomer sealing provides leakproof and low friction operation throughout entire pressure range.

**Viton Sealing**  
Provides superior wear and temperature protection.

**3-Way & 4-Way Valves, 2 & 3 Position**



## Solenoid Pilot



## Lever

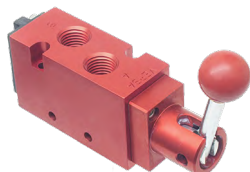

## Pilot

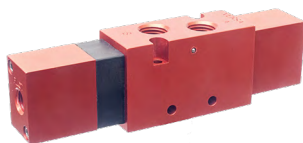

## Palm Button



## Rotary Button



# Features: Manifolds

## Manifolds/Plug-IN

**Plug-In plate Connects valve to manifold.**  
Same junction box is utilized for both single and double solenoid valves. All coils are factory pre-wired to junction box.

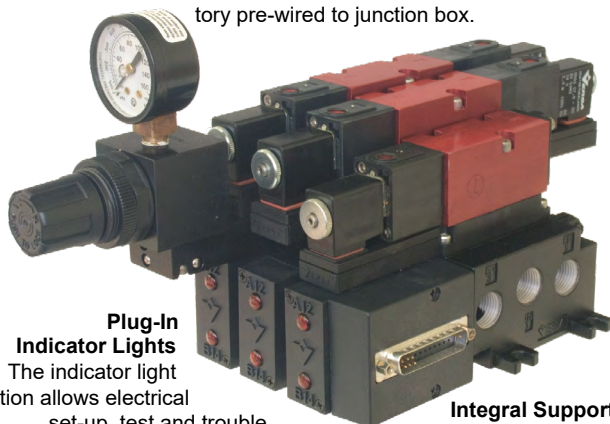

**Plug-In Indicator Lights**  
The indicator light option allows electrical set-up, test and trouble shooting capabilities, simplifying installation. Lights are easily retrofitted in the field.

**Integral Support Bracket Mounting**  
No extra parts or brackets are required in mounting complete valve/manifold assembly. Four very assessable mounting brackets simplify installation.

### Three Screws Fasten Valve to Manifold

Ease of installation and serviceability. No need to make or break any plumbing connections. Simple connect/disconnect of electrical connections when plug-in option is specified.

**Junction boxes** can be retrofitted in the field.

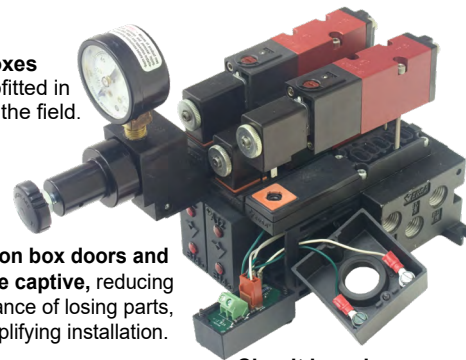

**Junction box doors and screws are captive**, reducing the chance of losing parts, therefore simplifying installation.

**Circuit board** with integral wiring terminal strip provides fast and easy installation.

## Rack Mounted

### 3-WAY VALVE & RACK MOUNT MANIFOLD

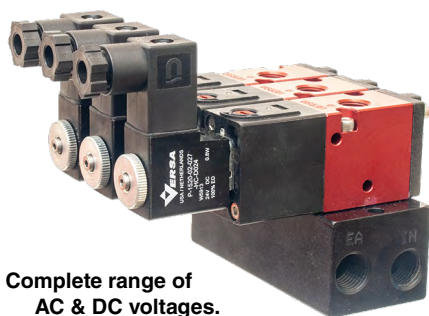

Complete range of AC & DC voltages.

Solenoid and Manual side ported Valves

### Many Solenoid Electrical Connections

- DIN connectors with cord grip or conduit connection
- Conduit connection
- Spade terminals
- Wire leads

### Regulator

Sandwich regulator 4 and 5 WAY (Dual pressure 4-Way).



# Specification

OPERATING PRESSURE						
Valve Type	Actuation	Pilot Type	Series	Port Size	Operating Pressure Range	Auxiliary Pilot Pressure
5/2 & 5/3	Single solenoid	Inpilot	C5	1/8" NPT	15-115 psi (1-8 bar)	none required
			C7	1/4" NPT	25-115 psi (1.7-8 bar)	
			C9	1/2" NPT	30-150 psi (2.1-10.3 bar)	
	Double solenoid or Double pilot-spring centered	Expilot	C5	1/8" NPT	Vacuum-115 psi (Vacuum-8 bar)	15-115 psi (1-8 bar)
			C7	1/4" NPT	Vacuum-115 psi (Vacuum-8 bar)	25-115 psi (1.7-8 bar)
			C9	1/2" NPT	Vacuum-150 psi (Vacuum-10.3 bar)	30-150 psi (2.1-10.3 bar)
5/2	Double solenoid-momentary contact	Inpilot	C5	1/8" NPT	10-115 psi (0.7-8 bar)	none required
			C7	1/4" NPT	15-115 psi (1-8 bar)	
			C9	1/2" NPT	20-150 psi (1.4-10.3 bar)	
	Double solenoid-momentary contact or Double pilot-momentary pressure	Expilot	C5	1/8" NPT	Vacuum-115 psi (Vacuum-8 bar)	10-115 psi (0.7-8 bar)
			C7	1/4" NPT	Vacuum-115 psi (Vacuum-8 bar)	15-115 psi (1-8 bar)
			C9	1/2" NPT	Vacuum-150 psi (Vacuum-10.3 bar)	20-150 psi (1.4-10.3 bar)
5/2 & 5/3	Manual-Lever, Button or Rotary switch		C5	1/8" NPT	Vacuum-115 psi (Vacuum-8 bar)	not applicable
			C7	1/4" NPT	Vacuum-115 psi (Vacuum-8 bar)	

## SPECIFICATIONS

<b>Temperature</b> Ambient Range:	-15°C (5°F) to +50°C (125°F) (Std) -15°C (5°F) to +203°F (95°C) Suffix Detail (-ET, -ETM)
<b>Flow/Size</b>	C5: 1/8" NPT/Cv: 0.75 C7: 1/4" NPT/Cv: 1.5 C9: 1/2" NPT/Cv: 4.1
<b>Installation</b>	C Series valves have no limitations on mounting orientation.
<b>Filtration &amp; Lubrication</b>	40 to 50 micron filtration, and use of general purpose, non-detergent lubricating oil (ISO, ASTM) Grade 32 is recommended.

<b>Materials, Valves</b>	
Valve body, plunger:	Anodized Aluminum
Actuating caps:	
Solenoid (Standard):	Anodized Aluminum
Solenoid (Low-Watt):	Synthetic Resin
Pilot	Anodized Aluminum
Manual	Anodized Aluminum
Spring Cap:	Synthetic Resin
Pilot Piston:	Synthetic Resin
Valve Seals:	Plunger & Body - FKM (fluorocarbon) Pilot Piston -NBR (nitrile)
Solenoid Parts (wetted):	304, 430F Stainless Steel and Brass

<b>Materials Manifolds</b>	
Manifold, End Plates:	Die cast Aluminum, powder coat-epoxy painted
Bleed Control Plate, Junction Box:	Synthetic Resin
Regulator Accessory Plate:	Black Anodized Aluminum
Station Blank:	Black Oxide Steel
Track-gaskets:	NBR (nitrile)
Screws: Manifold to Manifold:	Black Oxide Steel
Valve to Manifold:	Stainless Steel



## VALVE SELECTOR CHART & PRODUCT NUMBERING

C	SG	— 4	5	2	1	— 228L	— Coil Code		
	ACTUATING DEVICES		FUNCTION	PORT SIZE	TYPE OF BODY	SPOOL DETAILS (flow pattern)	Suffix Details		
SERIES C	SG	Spring Return, Solenoid	3 Three Way	2 1/8" NPT	0 <b>EXPILOT</b> For Manual, Pilot and Expiilot solenoid actuated valves**	Three-Way 3/2 1 2 Position, Normally Closed	<b>Coil/Coil Housing</b> -027 0.75 Low Watt DC Solenoid Operator -043 Low Watt AC/DC Solenoid Operator -228L 1/2" conduit -243 Wire leads -C50 1/2" conduit, 8 watt, steel housing -CB 48" coil wire lead length -CD 72" coil wire lead length -HC DIN interface, pg grip cord connector -HCC DIN interface, 1/2" conduit connector -HCLL DIN interface, 1/2" conduit connector with light -HCL DIN interface, pg grip cord connection with light -HT High temperature coil, class H -PC Potted coil, NEMA 4/4X, female hub (See page 12 - 14) <b>Hazardous Service Solenoids</b> -XX Hazardous Location Solenoid -XV Hazardous Location Solenoid -XT ATEX Flameproof solenoid <b>Manual Overrides</b> -G Override, gaurded -CML Override, un-guarded, locking -M Override, un-guarded, non-locking <b>Special Service/Lubrication</b> -55A FDA approved -55G Dow High vacuum -55M Dow Molykote 33 -H2 1/2" exhaust adapter -L14 Dust filter on solenoid exhaust -ET High Temp Service w/o override (C5 & C7) -ETM High Temp Service with override (C5 & C7)	Solenoid actuated valves require a Coil Code (see page 13) that indicates the specific coil current/frequency and voltage. The Coil Code consists of a letter to indicate the current frequency: <b>Rating Code:</b> A= 60Hz frequency D= Direct Current (DC) E= 50Hz frequency Three numbers follow the Rating Code to indicate voltage: <b>Examples:</b> Voltage Code 24V60 = A024 120V60 = A120 24VDC = D024	
	GG	Solenoid - Pilot (Dual Coil)							4 Four-Way
	XX	Spring Centering, Solenoid (Dual Coil)							
	SP	Spring Return, Pilot	C5 C7 C9	5 1/2" NPT		1 <b>EXPILOT MANIFOLD MOUNTING</b> For manifold mounting.			2 2-Position, Normally Open
	PP	Pressure Pilot (Dual Pilot)							
	JJ	Spring Centering, Pressure Pilot (Dual Pilot)	C5 C7	5 1/2" NPT		2 <b>INPILOT</b> Has an auxiliary internal passage to supply Inpilot† type solenoid			3 3 Position, All ports blocked at center
	SI	Spring Return, Palm Button							
	BI	Spring Centering, Palm Button	C5 C7	5 1/2" NPT	3 <b>INPILOT MANIFOLD MOUNTING</b> Has internal auxiliary passage to supply Inpilot† type solenoid and pilot actuators	4 3 Position, Cylinder ports open to exhaust at Center			
	SL	Spring Return, Lever							
	BL	Spring Centering, Lever	C5 C7	5 1/2" NPT	3 <b>INPILOT MANIFOLD MOUNTING</b> Has internal auxiliary passage to supply Inpilot† type solenoid and pilot actuators	8 3 Position, Inlet(s) open to both cylinder ports at center			
	ZL	Two-Detent, Lever							
	UL	Three-Detent, Lever	C5 C7	5 1/2" NPT	3 <b>INPILOT MANIFOLD MOUNTING</b> Has internal auxiliary passage to supply Inpilot† type solenoid and pilot actuators	8 3 Position, Inlet(s) open to both cylinder ports at center			
ZI	Two-Detent, Palm Button								
UI	Three-Detent, Palm Button	C5 C7	5 1/2" NPT	3 <b>INPILOT MANIFOLD MOUNTING</b> Has internal auxiliary passage to supply Inpilot† type solenoid and pilot actuators	8 3 Position, Inlet(s) open to both cylinder ports at center				
ZA	Two-Detent, Rotary Switch*								
UA	Three-Detent, Rotary Switch*	C5 C7	5 1/2" NPT	3 <b>INPILOT MANIFOLD MOUNTING</b> Has internal auxiliary passage to supply Inpilot† type solenoid and pilot actuators	8 3 Position, Inlet(s) open to both cylinder ports at center				

\*Rotary Switch must have -357 Suffix Detail

\*\*Separate pressure line connection needed to supply solenoid-pilot, differential pilot return or to control pressure pilot. †Internal auxiliary porting supplies pressurized medium being controlled to pilot, solenoid- pilot or differential pilot return.

### Repair Kit Series C5

Repair Kit		
3-Way	4-Way	For Valve Type
C-3201-SI	C-4202-SI	CSI-
C-3201-SL	C-4202-SL	CSL-
C-3201-ZI	C-4202-ZI	CZI-
C-3201-ZL	C-4202-ZL	CZL-
C-3203-BI	C-4203-BI	CBI-w/ 3 spool
C-3203-BL	C-4203-BL	CBL- w/ 3 spool
	C-4203-UI	CUI-w/ 3 spool
	C-4203-UL	CUL-w/ 3 spool
	C-4204-BI	CBI-w/ 4 spool
	C-4204-BL	CBL- w/ 4 spool
	C-4204-UI	CUI-w/ 4 spool
	C-4204-UL	CUL-w/ 4 spool
C-3221-PP	C-4222-PP	CGG- & CPP-
C-3221-SP	C-4222-SP	CSG- & CSP-
C-3223	C-4223	CXX- & CJJ- w/ 3 spool
C-3224	C-4224	CXX- & CJJ- w/ 4 spool

### Repair Kit Series C7

Repair Kit		
3-Way	4-Way	For Valve Type
C-3301-SI	C-4302-SI	CSI-
C-3301-SL	C-4302-SL	CSL-
C-3301-ZI	C-4302-ZI	CZI-
C-3301-ZL	C-4302-ZL	CZL-
C-3303-BI	C-4303-BI	CBI-w/ 3 spool
C-3303-BL	C-4303-BL	CBL- w/ 3 spool
	C-4303-UI	CUI-w/ 3 spool
	C-4303-UL	CUL-w/ 3 spool
	C-4304-BI	CBI-w/ 4 spool
	C-4304-BL	CBL- w/ 4 spool
	C-4304-UI	CUI-w/ 4 spool
	C-4304-UL	CUL-w/ 4 spool
C-3321-PP	C-4322-PP	CGG- & CPP-
C-3321-SP	C-4322-SP	CSG- & CSP-
C-3323	C-4323	CXX- & CJJ- w/ 3 spool
C-3324	C-4324	CXX- & CJJ- w/ 4 spool

### Repair Kit Series C9

Repair Kit No.	For Valve Type
C-4522-PP	CGG- & CPP-
C-4522-SP	CSG- & CSP-
C-4523	CXX- & CJJ- w/ 3 spool
C-4524	CXX- & CJJ- w/ 4 spool







### General Purpose Solenoid Replacement Part Numbers

VALVE TYPE	SERIES	SOLENOID TYPE	COIL TYPE	COIL PRODUCT NUMBER
Manifold Mounting or Body ported	C5 C7	Standard	3 spade terminals **	P-1005-02-HC-(*)
			Wire Leads	P-1005-02-243-(*)
			Wire Leads with 1/2" NPT conduit connection	P-1005-02-228L-(*)
	C5 C7	Low-Watt	3 spade terminals ††	†P-1520-02-027-HC-(*) †P-1520-02-043-HC-(*)
			Wire Leads	†P-1520-02-027-243-(*) †P-1520-02-043-243-(*)
			3 spade terminals ††	P-1580-02-HC-(*)
	C9	Standard	3 spade terminals ††	P-1580-02-HC-(*)

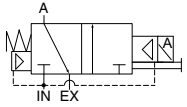
\*Add coil code from page 13  
 \*\*DIN connectors for this coil is P-1005-70-HC  
 † Match coil to valve product number using -027 or -043 designation (see page ??? for part number)  
 †† DIN connectors C5/C7 is P-1520-70-HC, C9 is P-1005-70-HC

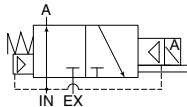
# VALVES

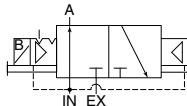
## SOLENOID ACTUATED, SPRING RETURN, SIDE PORT & MANIFOLD MOUNT

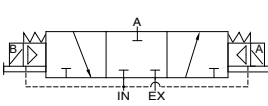
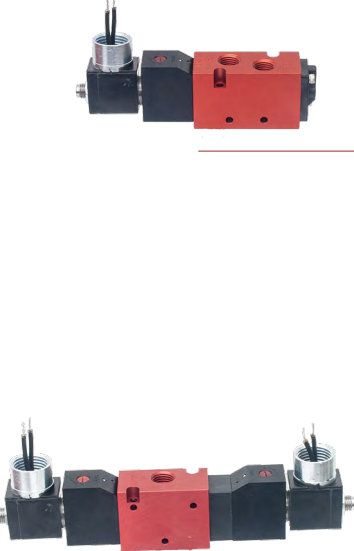
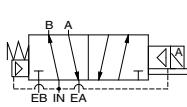
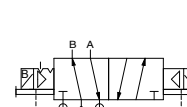
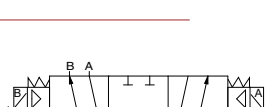
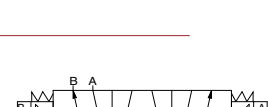
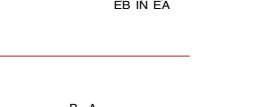
Side Ported	Function	Actuation	Pilot Type	Valve Series	Part Number		Flow Symbol
					Side Ported	Manifold Mount	
	3-Way 2-Position Normally Closed 3/2	Single Solenoid Spring Return	Inpilot	C5	CSG-3221-(*)	—	
				C7	CSG-3321-(*)	—	
			Expilot	C5	CSG-3201-(*)	—	
				C7	CSG-3301-(*)	—	
	3-Way 2-Position Normally Open 3/2	Single Solenoid Spring Return	Inpilot	C5	CGS-3222-(*)	—	
				C7	CGS-3322-(*)	—	
			Expilot	C5	CGS-3202-(*)	—	
				C7	CGS-3302-(*)	—	
	3-Way 2-Position 3/2	Double Solenoid Fail Last Position	Inpilot	C5	CGG-3221-(*)	—	
				C7	CGG-3321-(*)	—	
			Expilot	C5	CGG-3201-(*)	—	
				C7	CGG-3301-(*)	—	
	3-Way 3-Position 3/2	Double Solenoid Spring Center	Inpilot	C5	CXX-3223-(*)	—	
				C7	CXX-3323-(*)	—	
			Expilot	C5	CXX-3203-(*)	—	
				C7	CXX-3303-(*)	—	
	4-Way 2-Position 5/2	Single Solenoid Spring Return	Inpilot	C5	CSG-4222-(*)	CSG-4232-(*)	
				C7	CSG-4322-(*)	CSG-4332-(*)	
				C9	CSG-4522-(*)	CSG-4532-(*)	
			Expilot	C5	CSG-4202-(*)	CSG-4212-(*)	
				C7	CSG-4302-(*)	CSG-4312-(*)	
				C9	CSG-4502-(*)	CSG-4512-(*)	
	4-Way 2-Position 5/2	Double Solenoid Fail Last Position	Inpilot	C5	CGG-4222-(*)	CGG-4232-(*)	
				C7	CGG-4322-(*)	CGG-4332-(*)	
				C9	CGG-4522-(*)	CGG-4532-(*)	
			Expilot	C5	CGG-4202-(*)	CGG-4212-(*)	
				C7	CGG-4302-(*)	CGG-4312-(*)	
				C9	CGG-4502-(*)	CGG-4512-(*)	
4-Way 3-Position 5/3	Double Solenoid Spring Center (all ports blocked)	Inpilot	C5	CXX-4223-(*)	CXX-4233-(*)		
			C7	CXX-4323-(*)	CXX-4333-(*)		
			C9	CXX-4523-(*)	CXX-4533-(*)		
		Expilot	C5	CXX-4203-(*)	CXX-4213-(*)		
			C7	CXX-4303-(*)	CXX-4313-(*)		
			C9	CXX-4503-(*)	CXX-4513-(*)		
4-Way 3-Position 5/3	Double Solenoid Spring Center (cylinder ports open to exhaust)	Inpilot	C5	CXX-4224-(*)	CXX-4234-(*)		
			C7	CXX-4324-(*)	CXX-4334-(*)		
			C9	CXX-4524-(*)	CXX-4534-(*)		
		Expilot	C5	CXX-4204-(*)	CXX-4214-(*)		
			C7	CXX-4304-(*)	CXX-4314-(*)		
			C9	CXX-4504-(*)	CXX-4514-(*)		
4-Way 3-Position 5/3	Double Solenoid Spring Center (inlet open to cylinder port)	Inpilot	C5	CXX-4228-(*)	CXX-4238-(*)		
			C7	CXX-4328-(*)	CXX-4338-(*)		
			C9	CXX-4528-(*)	CXX-4538-(*)		
		Expilot	C5	CXX-4208-(*)	CXX-4218-(*)		
			C7	CXX-4308-(*)	CXX-4318-(*)		
			C9	CXX-4508-(*)	CXX-4518-(*)		

\* Add solenoid/coil voltages (page 13) & Suffix from Selector Chart (page 5)

## PILOT ACTUATED, SPRING RETURN, SIDE PORTED & MANIFOLD MOUNTED

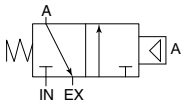
Side Ported	Function	Actuation	Valve Series	Part Number		Flow Symbol
				Body ported	Manifold mount	
	3-Way 2-Position Normally Closed 3/2	Single Pilot Spring Return	C5	CSP-3201	—	
			C7	CSP-3301	—	



**PILOT ACTUATED, SPRING RETURN, SIDE PORT & MANIFOLD MOUNT (cont.)**

Side Ported	Function	Actuation	Valve Series	Part Number		Flow Symbol
				Body ported	Manifold mount	
	3-Way 2-Position- Normally Open 3/2	Single Pilot Spring Return	C5	CPS-3202		
			C7	CPS-3302		
	3-Way 3-Position 3/2	Double Pilot	C5	CPP-3201		
			C7	CPP-3301		
	4-Way 2-Position 5/2	Single Pilot Spring Return	C5	CSP-4202	CSP-4212	
			C7	CSP-4302	CSP-4312	
	4-Way 2-Position 5/2	Double Pilot	C5	CPP-4202	CPP-4212	
			C7	CPP-4302	CPP-4312	
	4-Way 3-Position 5/3	Double Pilot Spring Center (all ports blocked)	C5	CJJ-4203	CJJ-4213	
			C7	CJJ-4303	CJJ-4313	
	4-Way 3-Position 5/3	Double Pilot Spring Center (cylinder ports open to exhaust)	C5	CJJ-4204	CJJ-4214	
			C7	CJJ-4304	CJJ-4314	
	4-Way 3-Position 5/3	Double Pilot Spring Center (inlet open to cylinder port)	C5	CJJ-4208	CJJ-4218	
			C7	CJJ-4308	CJJ-4318	
	4-Way 3-Position 5/3	Double Pilot Spring Center (inlet open to cylinder port)	C9	CJJ-4503	CJJ-4513	
			C9	CJJ-4504	CJJ-4514	
	4-Way 3-Position 5/3	Double Pilot Spring Center (inlet open to cylinder port)	C9	CJJ-4508	CJJ-4518	
			C9	CJJ-4508	CJJ-4518	

**PALM BUTTON ACTUATED, SPRING RETURN, SIDE PORT & MANIFOLD MOUNT**



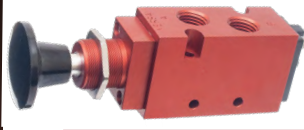
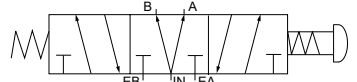

VALVES	Function	Actuation	Valve Series	Part Number		Flow Symbol
				Side Ported	Manifold Mount	
	3-Way 2-Position Normally Closed 3/2	Palm Button Spring Return	C5	CSI-3201	—	
			C7	CSI-3301	—	
	3-Way 2-Position Normally Open 3/2	Palm Button Spring Return	C5	CIS-3202	—	
			C7	CIS-3302	—	
	3-Way 3-Position 3/3	Palm Button Spring Return	C5	CBI-3203	—	
			C7	CBI-3303	—	
	4-Way 2-Position 5/2	Palm Button Spring Return	C5	CSI-4202	—	
			C7	CSI-4302	—	
	4-Way 3-Position 5/3	Palm Button Spring Center (all ports blocked)	C5	CBI-4203	CBI-4213	
			C7	CBI-4303	CBI-4313	
	4-Way 3-Position 5/3	Palm Button Spring Center (cylinder ports open to exhaust)	C5	CBI-4204	CBI-4214	
			C7	CBI-4304	CBI-4314	

# VALVES

## PALM BUTTON, ACTUATED, SPRING RETURN, SIDE PORT & MANIFOLD MOUNT (Cont.)

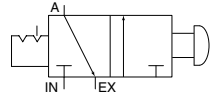
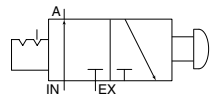
VALVES	Function	Actuation	Valve Series	Part Number		Flow Symbol
				Side Ported	Manifold Mount	
	4-Way 3-Position 5/3	Palm Button Spring Center (Inlet open to cylinder ports)	C5	CBI-4208	CBI-4218	
			C7	CBI-4308	CBI-4318	

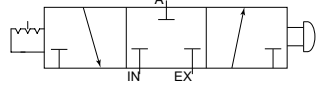
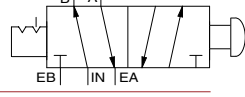
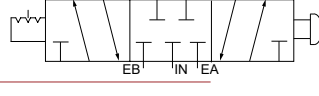
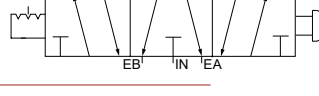
## PALM BUTTON ACTUATED, DETENTED, SIDE PORT & MANIFOLD MOUNT

VALVES	Function	Actuation	Valve Series	Part Number		Flow Symbol
				Side Ported	Manifold Mount	
	3-Way 2-Position Normally Closed 3/2	Palm Button Detent	C5	CZI-3201	—	
			C7	CZI-3301	—	
	3-Way 2-Position- Normally Open 3/2	Palm Button Detent	C5	CIZ-3202	—	
C7	CIZ-3302	—				
	3-Way 3-Position 3/3	Palm Button 3 Detent (all ports blocked)	C5	CUI-3203	—	
			C7	CUI-3303	—	
	4-Way 2-Position 5/2	Palm Button 2 Detent	C5	CZI-4202	CZI-4212	
			C7	CZI-4302	CZI-4312	
4-Way 3-Position 5/3	Palm Button 3 Detent (all ports blocked)	C5	CUI-4203	CUI-4213		
		C7	CUI-4303	CUI-4313		
4-Way 3-Position 5/3	Palm Button 3 Detent (cylinder ports open to exhaust)	C5	CUI-4204	CUI-4214		
		C7	CUI-4304	CUI-4314		
4-Way 3-Position 5/3	Palm Button 3 Detent (Inlet open to cylinder ports)	C5	CUI-4208	CUI-4218		
		C7	CUI-4308	CUI-4318		

## ROTARY SWITCH ACTUATED, DETENTED, SIDE PORT & MANIFOLD MOUNT

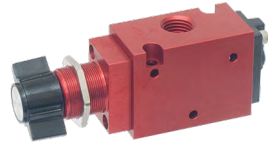
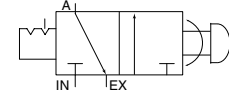
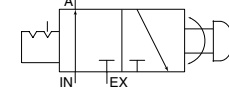
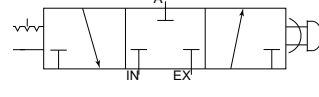
VALVES	Function	Actuation	Valve Series	Part Number		Flow Symbol
				Side Ported	Manifold Mount	
	3-Way 2-Position Normally Closed 3/2	Palm Button 2 Detent	C5	CZA-3201-357-(* )	—	
			C7	CZA-3301-357-(* )	—	
	3-Way 2-Position Normally Open 3/2	Palm Button 2 Detent	C5	CAZ-3202-357-(* )	—	
C7			CAZ-3302-357-(* )	—		
3-Way 3-Position 3/3	Palm Button 3 Detent (all ports blocked)	C5	CUA-3203-357-(* )	—		
		C7	CUA-3303-357-(* )	—		

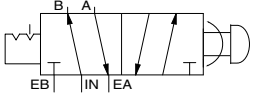
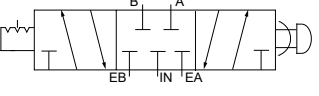
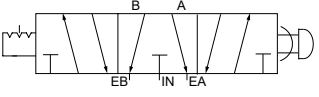
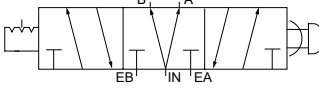

## ROTARY SWITCH, ACTUATED, DETENTED, SIDE PORT & MANIFOLD MOUNT (Cont.)

VALVES	Function	Actuation	Valve Series	Part Number		Flow Symbol
				Side Ported	Manifold Mount	
	4-Way 2-Position 5/2	Palm Button 2 Detent	C5	CZA-4202-357-(*)	CZA-4212-357-(*)	
			C7	CZA-4302-357-(*)	CZA-4312-357-(*)	
	4-Way 3-Position 5/3	Palm Button 3 Detent (all ports blocked)	C5	CUA-4203-357-(*)	CUA-4213-357-(*)	
			C7	CUA-4303-357-(*)	CUA-4313-357-(*)	
		Palm Button 3 Detent (cylinder ports open to exhaust)	C5	CUA-4204-357-(*)	CUA-4214-357-(*)	
			C7	CUA-4304-357-(*)	CUA-4314-357-(*)	
		Palm Button 3 Detent (Inlet open to cylinder ports)	C5	CUA-4208-357-(*)	CUA-4218-357-(*)	
			C7	CUA-4308-357-(*)	CUA-4318-357-(*)	

\*Options for Manually Actuated Palm Button Valves  
 Suffix Push Button Knob Color  
 -25B Large diameter 1.81" (46mm) black button.  
 -25BG Large diameter 1.81" (46mm) green button.  
 -25BR Large diameter 1.81" (46mm) red button.

## LEVER ACTUATED, SPRING RETURN, SIDE PORT & MANIFOLD MOUNT

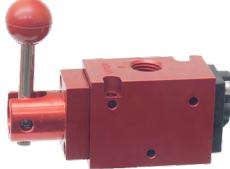
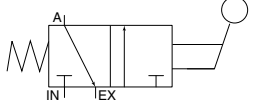
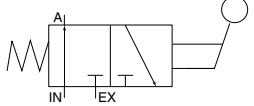
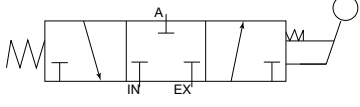
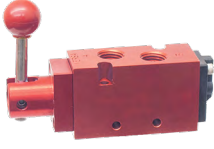
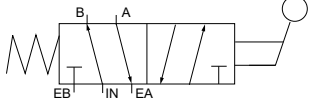
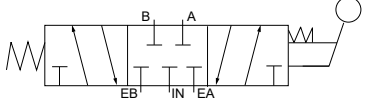
VALVES	Function	Actuation	Valve Series	Part Number		Flow Symbol
				Side Ported	Manifold Mount	
	3-Way 2-Position Normally Closed 3/2	Lever Spring Return	C5	CSL-3201-(*)	—	
			C7	CSL-3301-(*)	—	
	3-Way 2-Position Normally Open 3/2	Lever Spring Return	C5	CLS-3202-(*)	—	
			C7	CLS-3302-(*)	—	
	3-Way 3-Position 3/3	Lever Spring Return	C5	CBL-3203-(*)	—	
			C7	CBL-3303-(*)	—	
	4-Way 2-Position 5/2	Lever Spring Return	C5	CSL-4202-(*)	CSL-4212-(*)	
			C7	CSL-4302-(*)	CSL-4312-(*)	
	4-Way 3-Position 5/3	Lever Spring Center (all ports blocked)	C5	CBL-4203-(*)	CBL-4213-(*)	
			C7	CBL-4303-(*)	CBL-4313-(*)	

# VALVES

## LEVER ACTUATED, SPRING RETURN, SIDE PORT & MANIFOLD MOUNT (CONT.)

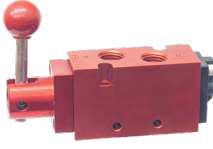
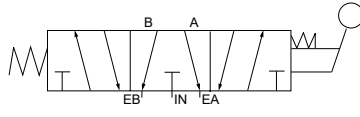
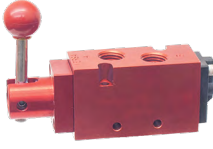
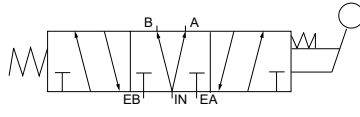
VALVES	Function	Actuation	Valve Series	Part Number		Flow Symbol
				Side Ported	Manifold Mount	
	4-Way 3-Position 5/3	Lever Spring Center (cylinder ports open to exhaust)	C5	CBL-4204-(* )	CBL-4214-(* )	
			C7	CBL-4304-(* )	CBL-4314-(* )	
	4-Way 3-Position 5/3	Lever Spring Center (inlet open to cylinder ports)	C5	CBL-4208-(* )	CBL-4218-(* )	
			C7	CBL-4308-(* )	CBL-4318-(* )	

## LEVER ACTUATED, DETENTED, SIDE PORT & MANIFOLD MOUNT

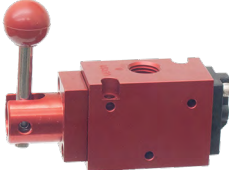
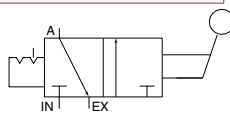
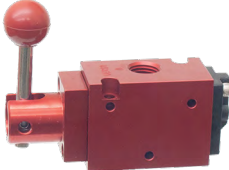
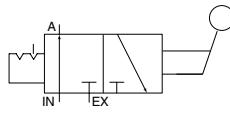
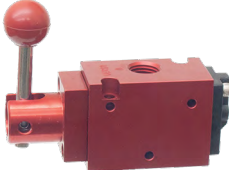
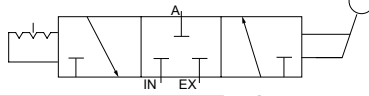
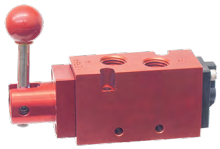
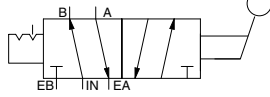
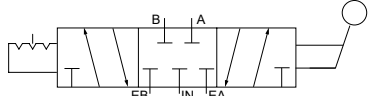
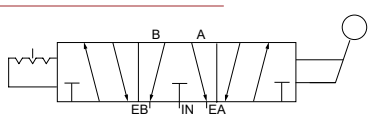
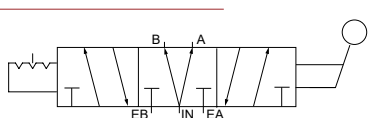
VALVES	Function	Actuation	Valve Series	Part Number		Flow Symbol
				Side Ported	Manifold Mount	
	3-Way 2-Position Normally Closed 3/2	Lever 2 Detent	C5	CZL-3201-(* )	—	
			C7	CZL-3301-(* )		
	3-Way 2-Position Normally Open 3/2	Lever 2 Detent	C5	CLZ-3202-(* )	—	
			C7	CLZ-3302-(* )		
	3-Way 3-Position 3/3	Lever 2 Detent	C5	CUL-3203-(* )	—	
			C7	CUL-3303-(* )		
	4-Way 2-Position 5/2	Lever 2 Detent	C5	CZL-4202-(* )	CZL-4212-(* )	
			C7	CZL-4302-(* )	CZL-4312-(* )	
	4-Way 3-Position 5/3	Lever 3 Detent (all ports blocked)	C5	CUL-4203-(* )	CUL-4213-(* )	
			C7	CUL-4303-(* )	CUL-4313-(* )	
4-Way 3-Position 5/3	Lever 3 Detent (cylinder ports open to exhaust)	C5	CUL-4204-(* )	CUL-4214-(* )		
		C7	CUL-4304-(* )	CUL-4314-(* )		
4-Way 3-Position 5/3	Lever 3 Detent (inlet open to cylinder ports)	C5	CUL-4208-(* )	CUL-4218-(* )		
		C7	CUL-4308-(* )	CUL-4318-(* )		

\*-43 Additional panel nut for button or rotary switch valves. Reduces panel thickness from 0.56" (14.2) to 0.44" (11mm).

\*Options for Manually Actuated Palm Button Valves

Suffix Lever Handle Position

-218A Lever is rotated 90° counter clockwise from vertical upright position.

-218B Lever is rotated 180° counter clockwise from vertical upright position.

-218C Lever is rotated 270° counter clockwise from vertical upright position



## GENERAL PURPOSE COILS

	Coil Description CLASS F, Epoxy encapsulated, Rated voltage continuous duty 100%	Agency Approvals	Suffix Details by Series			CONTINUOUS DUTY COILS					
			C5	C7	C9	Nominal Power		AC Voltage		DC Voltage	
						AC	DC	Volts Hz	Coil Code#	Volts	Coil Code#
	3 spade terminals, 11 mm, Mini DIN (DIN 43650 Form B), IP65 Override Options: -M & CML*	UR CSA	-C8	-C8	Std	Max VA 6.8	Max Watts 5.9	24/60 110/50 120/60 220/50 240/50 240/60	A024 E110 A120 E220 A240 A240	6 12 24 48	D006 D012 D024 D048
	3 spade terminals, 11 mm, Mini DIN (DIN 43650 Form B) Pg9 cord grip, IP65 Override Options: -M & CML*		-C8 -HC	-C8 -HC	-HC						
	3 spade terminals, 11 mm, For use with 1/2" NPT Mini DIN con- nector (DIN 43650 Form B), IP65 Override Options: -M & CML*		-C8 -HCC	-C8 -HCC	-HCC						
	Two Leads (flying leads). Override Options: -G, -M & CML*		-243	-243	-C15 -243	8.5 Watts	10.5 Watts				
	1/2" NPT conduit entry; integrally molded coil and conduit entry, NEMA 1, 2, 3 Override Options: -G, -M & CML*		-228L	-228L	-C15 -228L						
	1/2" NPT conduit entry, carbon steel chromate coated. Override Options: -G, -M & CML*		-C50	-C50	-C50	6 Watts	7 Watts			12 24 48 125	D012 D024 D048 D125
	1/2" NPT conduit entry; potted coil NEMA 4, 4X, 11, 12, and 13, carbon steel chromate coated. Override Options: -G, -M & CML*		-C50 -PC	-C50 -PC	-C50 -PC						

## LOW WATT Options -027 & -043

	Coil Description	Suffix Detail by Series			CONTINUOUS DUTY COILS						
		C5	C7	C9	Nominal Power		DC Voltage		AC Voltage		
					DC	AC	Volts	Coil Code#	Volts	Coil Code#	
	CLASS F, Epoxy encapsulated, Rated voltage continuous duty 100%	-027	-027	N/A	0.75 Watt	—	12 24 48	D012 D024 D048	—	—	
	3 spade terminals, 8 mm, micro mini DIN (DIN 43650 "C"). Overrides: M & CML	-043	-043	N/A	2.9 Watt	—					
	Available: Pg7 cord grip (Suffix Detail -HC), Wire leads (Suffix Detail -243) Plug-In manifold connection (Suffix Detail -P)				3.7 Watt	24 120 240					







### \*Overrides

Four types of overrides are available: Suffix Detail -G, -G5R (standard), -M and -CML. The -G5R (standard) is a push twist to lock, requires no call out. -G is a guarded momentary contact, -M is an unguarded momentary contact and -CML is a raised grip, push twist to lock.

Three styles are available depending on the solenoid pilot cap used; one made of, engineered polymer or two made of aluminum. The engineered polymer (shown top): -M, G5R (standard) & -CML. Aluminum (shown middle): -M, -G5R (standard), -CML & -G. Aluminum (shown bottom): -M, -G5R (standard) & -CML. (see chart above for applicable coil and override).

## HAZARDOUS LOCATION SOLENOID OPERATOR SPECIFICATIONS

Solenoid/Pilot actuated C Series valves are available with a variety of different solenoids for hazardous locations. Basic details of actuators are listed below. For additional data consult factory.

Hazardous Location Solenoids								
			Agency Approvals					
			North America		World*			
			SP		Ex IEC IECEx			
	Suffix*	Protection Classification	Zones	Divisions	Area Classification and (Gas Grouping)	Agency	Ingress Protection	
	-XX	Hazardous Locations	—	CL I, DIV 1, Grp (C & D) CL II, DIV 1, Grp (E, F & G) Temp T3C	—	UL CSA	NEMA 7 & 9	
				CL I, DIV 2 Grp (A B C) CL II, DIV 2 Grp (E, F & G) Temp T3C				
	XN	(d) Flameproof	—	—	Ex d IIB+H2 T3...T6 Gb II 2 G Ex d IIB+H2 T3...T6 Gb	IECEX ATEX	IP66 IP67	
	-XV	Hazardous Locations	—	CL I, DIV 1, Grp (B, C, D) CL II, DIV 1, Grp (E, F, G) CL III CL I, DIV 2, Grp (A, B, C, D) CL II, DIV 1, Grp (E, F, G) CL III	—	cCSA <sub>US</sub>	NEMA 4, 4X, 6P, IP66	
	-XT	(d) Flameproof						
	-XDBT	(d) Flameproof	CL, I, Zn 1 A/Ex de IIC T CL, II Zn, 21 AEx tD A21, DIP A21	—	Ex II 2 G D A/Ex d e IIC T3...T6 Gb Ex tb IIIC T3...T6 Db	ATEX, IECEX, INMETRO	IP66 IP67 IP68	
	-XDBS							
See page 14 for -XX, -XN, -XV, -XT, & -XDB Solenoid options								
	-HC -XISX6 (Shown)	Intrinsic Safe	—	CL I, DIV 1, Grp (A, B, C & D) CL II, DIV 1, Grp (E, F & G) CL III	II 2 G Ex ia IIC T4...T6 Gb II 2 G Ex ia IIB T4...T6 Gb	ATEX IECEX TR CU CSA FM	IP65	
	-HCC -XISX6							



**COIL CODES:** Identify the solenoid frequency and voltage, consisting of a "Rating Code" and "Voltage" as shown at right. Coil codes complete the part number for a solenoid operated valve.

**Rating Code**  
 A = 60Hz frequency  
 D = Direct Current (DC)  
 E = 50Hz frequency

**Voltage**  
 Indicated by three digits:  
 e.g. 24 volts = 024  
 120 volts = 120

**A120 = AC, 120Volts/60hz**

	Voltage (Power)	Electrical Characteristics	Miscellaneous																																																														
	50 Hz & 60 Hz AC (6W), DC (7.2W) & (1.8W) AC: 12V60 (A012), 24V60 (A024), 48V60 (A048), 120V60 (A120), 240V60 (A120) DC: 6VDC (D006), 12VDC (D012), 24VDC (D024), 48VDC (D048)	Class F epoxy molded coil (155°C). continuous duty. 3 leads 24" (60 cm).	Plated steel coil housing with 1/2 NPT conduit entry. For additional solenoid options see pages 5																																																														
	AC: 120V60HZ (A120), 240V60HZ (A240) 110V50HZ (E110), 220V50HZ (E230) DC: 12VDC (D012), 24VDC (D024) 48VDC (D048), 120VDC (D120) 1.8 watt standard. For 0.85 watt consult factory.	Epoxy molded coils rated for continuous duty, Class H (180°C).	<table border="1"> <thead> <tr> <th rowspan="2">Stainless steel coil housing with 1/2" NPT conduit connection.</th> <th colspan="2">Suffix Detail Ordering Code</th> </tr> <tr> <th>XV</th> <th>XT</th> </tr> </thead> <tbody> <tr> <td></td> <td colspan="2">1.8 watt</td> </tr> <tr> <td>Standard (vent to atmosphere)</td> <td>-XV1</td> <td>-XT1</td> </tr> <tr> <td>1/8" Adapter (-H2E)</td> <td>-XV2</td> <td>-XT2</td> </tr> <tr> <td>1/4" Adapter (-HE)</td> <td>-XV3</td> <td>-XT3</td> </tr> <tr> <td>Dust Nut (-L14)</td> <td>-XV4</td> <td>-XT4</td> </tr> <tr> <td>Water proof nut (-D14)</td> <td><b>-XV9*</b></td> <td><b>-XT9*</b></td> </tr> </tbody> </table> <table border="1"> <thead> <tr> <th rowspan="2">Stainless steel coil housing with internal Junction Box. Internal and external ground screw.</th> <th colspan="4">Suffix Detail Ordering Code</th> </tr> <tr> <th colspan="2">M 20 Connection</th> <th colspan="2">1/2" Connection</th> </tr> <tr> <td></td> <th>No Diode</th> <th>Diode</th> <th>No Diode</th> <th>Diode</th> </tr> </thead> <tbody> <tr> <td>Standard (vent to atmosphere)</td> <td>XDBS1</td> <td>XDBS5</td> <td>XDBT1</td> <td>XDBT5</td> </tr> <tr> <td>1/8" Adapter (-H2E)</td> <td>XDBS2</td> <td>XDBS6</td> <td>XDBT2</td> <td>XDBT6</td> </tr> <tr> <td>1/4" Adapter (-HE)</td> <td>XDBS3</td> <td>XDBS7</td> <td>XDBT3</td> <td>XDBT7</td> </tr> <tr> <td>Dust Nut (-L14)</td> <td>XDBS4</td> <td>XDBS8</td> <td>XDBT4</td> <td>XDBT8</td> </tr> <tr> <td>Dust Excluder (-D14)</td> <td><b>XDBS9*</b></td> <td><b>XDBS10</b></td> <td><b>XDBT9*</b></td> <td><b>XDBT10*</b></td> </tr> </tbody> </table>	Stainless steel coil housing with 1/2" NPT conduit connection.	Suffix Detail Ordering Code		XV	XT		1.8 watt		Standard (vent to atmosphere)	-XV1	-XT1	1/8" Adapter (-H2E)	-XV2	-XT2	1/4" Adapter (-HE)	-XV3	-XT3	Dust Nut (-L14)	-XV4	-XT4	Water proof nut (-D14)	<b>-XV9*</b>	<b>-XT9*</b>	Stainless steel coil housing with internal Junction Box. Internal and external ground screw.	Suffix Detail Ordering Code				M 20 Connection		1/2" Connection			No Diode	Diode	No Diode	Diode	Standard (vent to atmosphere)	XDBS1	XDBS5	XDBT1	XDBT5	1/8" Adapter (-H2E)	XDBS2	XDBS6	XDBT2	XDBT6	1/4" Adapter (-HE)	XDBS3	XDBS7	XDBT3	XDBT7	Dust Nut (-L14)	XDBS4	XDBS8	XDBT4	XDBT8	Dust Excluder (-D14)	<b>XDBS9*</b>	<b>XDBS10</b>	<b>XDBT9*</b>	<b>XDBT10*</b>
Stainless steel coil housing with 1/2" NPT conduit connection.	Suffix Detail Ordering Code																																																																
	XV	XT																																																															
	1.8 watt																																																																
Standard (vent to atmosphere)	-XV1	-XT1																																																															
1/8" Adapter (-H2E)	-XV2	-XT2																																																															
1/4" Adapter (-HE)	-XV3	-XT3																																																															
Dust Nut (-L14)	-XV4	-XT4																																																															
Water proof nut (-D14)	<b>-XV9*</b>	<b>-XT9*</b>																																																															
Stainless steel coil housing with internal Junction Box. Internal and external ground screw.	Suffix Detail Ordering Code																																																																
	M 20 Connection		1/2" Connection																																																														
	No Diode	Diode	No Diode	Diode																																																													
Standard (vent to atmosphere)	XDBS1	XDBS5	XDBT1	XDBT5																																																													
1/8" Adapter (-H2E)	XDBS2	XDBS6	XDBT2	XDBT6																																																													
1/4" Adapter (-HE)	XDBS3	XDBS7	XDBT3	XDBT7																																																													
Dust Nut (-L14)	XDBS4	XDBS8	XDBT4	XDBT8																																																													
Dust Excluder (-D14)	<b>XDBS9*</b>	<b>XDBS10</b>	<b>XDBT9*</b>	<b>XDBT10*</b>																																																													
	24VDC (1.6 watt max.) System voltage prior to barrier	Class F epoxy molded coil (155°C). Continuous duty.	Requires the use of an approved barrier or isolator. Maximum operating system voltage before barrier 28VDC. Maximum pilot pressure 115 psi (8 bar). 3 spade terminals, ISO DIN 43650, Form "A" PG9 cable gland (-HC) 1/2 NPT conduit entry: (-HCC)																																																														

## Hazardous Location Combination Suffix Details

### Cross Reference Chart

Suffix Reference	
Suffix	Description
-CD	72" wire leads
-D14	Solenoid vent, water proof nut
-H2E	1/8" npt Solenoid vent
-HE	1/4" npt Solenoid vent
-HT	Class H coil
-L14	Solenoid vent dust nut
-LA	0.85 watt Solenoid
-LB	1.8 watt Solenoid
-LV	0.85 watt (World Solenoid)
-LX	1.8 watt (World Solenoid)
-LZ	0.5 watt (World Solenoid)
-PC	Potted coil, NEMA 4
-PS	Potted coil, male conduit;
-ST	Stainless Solenoid housing
-XDBS	World Solenoid**
-XDBT	World Solenoid**
-VJBT	Add on Junction Box
-XN	ATEX Solenoid
-XT	World Solenoid**
-XV	World Solenoid, North America
-XX	North American Solenoid
-303D	Integral diode

North American (-XX) (Cont.)	
Combination Suffix	Included Suffix
-XXK	-XX, -HT, -LB, -PC, -ST
-XXK4	-XX, -D14, -HT, -LB, -PC, -ST
-XXL	-XX, -PC
-XXL4	-XX, -D14, -PC
-XXM	-XX, -HT, -PC
-XXM4	-XX, -D14, -HT, -PC
-XXN	-XX, -LB, -PC
-XXN4	-XX, -D14, -LB, -PC
-XXP	-XX, -HT, -LB, -PC
-XXP4	-XX, -D14, -HT, -LB, -PC
-XXQ	-XX, -HT, -LB
-XXQ4	-XX, -D14, -HT, -LB
-XXR	-XX, -LB
-XXR4	-XX, -D14, -LB
-XXS	-XX, -LA, -ST
-XXS4	-XX, -D14, -LA, -ST
-XXU	-XX, -HT, -LB, -ST
-XXU4	-XX, -D14, -HT, -LB, -ST
-XXV	-XX, -LA
-XXV4	-XX, -D14, -LA
-XXW	-XX, -CD, -HT, -H2, -PC, -ST
-XXW4	-XX, -D14, -CD, -HT, -PC, -ST

ATEX (-XN) (Cont.)	
Combination Suffix	Included Suffix
-XNQ	-XN, -HT, -LB
-XNR	-XN, -LB
-XNS	-XN, -LA, -ST
-XNU	-XN, -HT, -LB, -ST
-XNV	-XN, -LA
-XNX	-XN, -LB, -PS
-XNWS	-XN, -VJBT, -LB, -PS

North American (-XX)	
Combination Suffix	Included Suffix
-XXA	-XX, -HT
-XXA4	-XX, -D14, -HT
-XXB	-XX, -PS
-XXB4	-XX, -D14, -PS
-XXC	-XX, -HT, -PS
-XXC4	-XX, -D14, -HT, -PS
-XXD	-XX, -ST
-XXD4	-XX, -D14, -ST
-XXE	-XX, -PC, -ST
-XXE4	-XX, -D14, -PC, -ST
-XXF	-XX, -HT, -ST
-XXF4	-XX, -D14, -HT, -ST
-XXG	-XX, -LB, -ST
-XXG4	-XX, -D14, -LB, -ST
-XXH	-XX, -HT, -PC, -ST
-XXH4	-XX, -D14, -HT, -PC, -ST
-XXJ	-XX, -LB, -PC, -ST
-XXJ4	-XX, -D14, -LB, -PC, -ST

ATEX (-XN)	
Combination Suffix	Included Suffix
-XNA	-XN, -HT
-XND	-XN, -ST
-XNE	-XN, -PC, -ST
-XNE4	-XN, D14, -PC, -ST
-XNF	-XN, -HT, -ST
-XNG	-XN, -LB, -ST
-XNH	-XN, -HT, -PC, -ST
-XNJ	-XN, -LB, -PC, -ST
-XNJ4	-XN, -D14, -LB, -PC, -ST
-XNK	-XN, -HT, -LB, -PC, -ST
-XNL	-XN, -PC
-XNL4	-XN, -D14, -PC
-XNM	-XN, -HT, -PC
-XNN	-XN, -LB, -PC
-XNN4	-XN, -D14, -LB, -PC
-XNP	-XN, -HT, -LB, -PC

World Solenoid (-XDB, -XT, -XV)		
Combination Suffix		Included Suffix
1.8 Watt	0.85 Watt	
-XDBS1	-XDBS1C	-XDBS, -HT, -LX
-XDBS2	-XDBS2C	-XDBS, -HT, -LX, -H2E
-XDBS3	-XDBS3C	-XDBS, -HT, -LX, -HE
-XDBS4	-XDBS4C	-XDBS, -HT, -LX, -L14
-XDBS5	-XDBS5C	-XDBS, -HT, -LX, -303D
-XDBS6	-XDBS6C	-XDBS, -HT, -LX, -H2E, -303D
-XDBS7	-XDBS7C	-XDBS, -HT, -LX, -HE, -303D
-XDBS8	-XDBS8C	-XDBS, -HT, -LX, -L14, -303D
-XDBS9	-XDBS9C	-XDBS, -HT, -LX, -D14
-XDBS10	-XDBS10C	-XDBS, -HT, -LX, -D14, -303D
-XDBT1	-XDBT1C	-XDBT, -HT, -LX
-XDBT2	-XDBT2C	-XDBT, -HT, -LX, -H2E
-XDBT3	-XDBT3C	-XDBT, -HT, -LX, -HE
-XDBT4	-XDBT4C	-XDBT, -HT, -LX, -L14
-XDBT5	-XDBT5C	-XDBT, -HT, -LX, -303D
-XDBT6	-XDBT6C	-XDBT, -HT, -LX, -H2E, -303D
-XDBT7	-XDBT7C	-XDBT, -HT, -LX, -HE, -303D
-XDBT8	-XDBT8C	-XDBT, -HT, -LX, -L14, -303D
-XDBT9	-XDBT9C	-XDBT, -HT, -LX, -D14
-XDBT10	-XDBT10C	-XDBT, -HT, -LX, -D14, -303D
-XV1	-XV1C	-XV, -HT, -LX
-XV2	-XV2C	-XV, -HT, -LX, -H2E
-XV3	-XV3C	-XV, -HT, -LX, -HE
-XV4	-XV4C	-XV, -HT, -LX, -L14
-XV9	-XV9C	-XV, -HT, -LX, -D14
-XT1	-XT1C	-XT, -HT, -LX
-XT2	-XT2C	-XT, -HT, -LX, -H2E
-XT3	-XT3C	-XT, -HT, -LX, -HE
-XT4	-XT4C	-XT, -HT, -LX, -L14
-XT9	-XT9C	-XT, -HT, -LX, -D14

### Recommended Hazardous Location Solenoid Option Packages

Enclosure/Wire	Certification/Power			
	North American - CSA		ATEX - IECEx - INMETRO	
	Standard Power	Low Watt*	Standard Power	Low Watt*
Steel, Electroless Nickel Plated, 24 Inch Leads	-XXL4	-XXN4	-XNL4	-XNN4
Stainless Steel, High Performance 430 type, 24 Inch leads	-XXE4	-XXJ4	-XNE4	-XNJ4
Stainless Steel, 316L type, Junction Box with Terminal Strip	n/a	-XDBT9**	n/a	-XDBS9

\* 1.8 watt solenoid. Also available is 0.85 watt, see cross reference chart above. For 0.50 watt, consult factory.

\*\* All the -XDBT type solenoids are "World Solenoids." Certified for North America, ATEX, IECEx and INMETRO

## Manifold Selector

C5M	4	2	0	2	6	PMR	SSD	XS	D024
Manifold Type Valve Size	Valve Type	Cylinder Port Size	Port Type	Cylinder Port Location	Number of Stations	Multi-Pin Connector	Surge Suppression	Isolation Plug	Voltage Code (required for Lights)
C5M - 1/8"	3 - 3-Way*	2 - 1/8"	0 - NPT	0 - Rack Mounted:	Rack Mounted:	None: Non Plug-In manifold	SSD	XS_* - Supply	D024 - DC 24 Volt
C7M - 1/4"	4 - 4-Way	3 - 1/4"	6 - ISO Threads	(cylinder ports are in the valve)	2 - 10	P: Plug-In manifold	DC coils only	XE_* - Exhaust	A120 - AC 120 Volt
C9M - 1/2"	*C5, C7 3-Way rack mount only. See page 19	4 - 3/8" 5 - 1/2"		2 - Stacking: Side 3 - Stacking: Side & Bottom	Stacking Manifold: 2 - 10 Multi Pin Connector: C5 & C7 2 - 12 C9: 2 - 8	PL: Plug-In manifold with lights* PM: Multi-Pin connector left hand side PML: Multi-Pin connector left hand side with lights* PMR: Multi-Pin connector right hand side PMRL: Multi-Pin connector right hand side with lights*		*Requires location of section to be isolated Example XS3 is the supply port 3rd interface from the left looking at cylinder ports	See Coil Code definition page 13
*Lights require voltage call out, see last column									

## Manifold Cylinder Port Size & Location

	Cylinder Port Size		Cylinder Port Location		Stacking Manifolds Non Plug-In		Stacking Manifolds Plug-In	
	1/8" NPT	1/4" NPT	Side Only	Side & Bottom	Manifold part Number	Mountable Valves, Typical	Manifold part Number	Mountable Valves
	Low Watt 027 or 043							
C5	X		X		C5M-4202-(t)	CSG-4232-(*) CGG-4232-(*) CXX-4233-(*) CXX-4234-(*)	C5M-4202-(t)-(tt)	CSG-4232-027-P-(*) CGG-4232-027-P-(*) CXX-4233-027-P-(*) CXX-4234-027-P-(*)
		X	X		C5M-4302-(t)		C5M-4302-(t)-(tt)	CSG-4232-043-P-(*) CGG-4232-043-P-(*) CXX-4233-043-P-(*) CXX-4234-043-P-(*)
	X			X	C5M-4203-(t)		C5M-4203-(t)-(tt)	
C7	1/4" NPT	3/8" NPT						
	X		X		C7M-4302-(t)		C7M-4302-(t)-(tt)	CSG-4332-027-P-(*) CGG-4332-027-P-(*) CXX-4333-027-P-(*) CXX-4334-027-P-(*)
		X	X		C7M-4402-(t)	CSG-4332-(*) CGG-4332-(*) CXX-4333-(*) CXX-4334-(*)	C7M-4402-(t)-(tt)	CSG-4332-043-P-(*) CXX-4333-043-P-(*) CGG-4332-043-P-(*) CXX-4334-043-P-(*)
C9	1/2" NPT	1/2" NPT						
	X		X		C9M-4502-(t)	CSG-4532-(*) CGG-4532-(*) CXX-4533-(*) CXX-4534-(*)	C9M-4502-(t)-(tt)	CSG-4532-P-(*) CGG-4532-P-(*) CXX-4533-P-(*) CXX-4534-P-(*)
	X			X	C9M-4503-(t)		C9M-4503-(t)-(tt)	

### Notes:

\* Voltage options - see page 11

† The number of stations - 2-12 (1/2" manifold limited to 8 stations with multi pin connector)

†† Plug-In manifold, Multi-Pin connector (Left & right orientation based on viewing manifold cylinder ports)

P Plug-In manifold

PL Plug-In manifold with lights\*

PM Multi-Pin connector left hand side

PML Multi-Pin connector left hand side with lights\*

PMR Multi-Pin connector right hand side

PMRL Multi-Pin connector right hand side with lights\*

\* Lights require same voltage option as solenoid operator being used  
ISO ports available on both valves and manifolds. Contact factory for part number.



Shown:

- 1 C7M-4402-3-PML-D024; Manifold
- 1 CSG-4332-027-P-D024; Valve, Single Solenoid
- 2 CGG-4332-027-P-D024; Valve, Dual Solenoid
- 1 C7AR-4125MG-P; Regulator



# Manifold Accessories

## Isolation Disc



### Isolation Disc (Suffix -XS\_)

Isolation Discs are small gasketed shields that can be placed between manifold stations, to effectively isolate a group of valves that utilize the same pressure.

## Intermediate Supply Plate

### Intermediate Supply Plate

(Suffix -SP\_) Provides a port for an external pneumatic supply, in applications where an additional air source is required to increase the available volume of air. Consult factory for application assistance.

Non Plug-In Valves	C5	C5M-4202-SP	0.55" wide	
	C7	C7M-4303-SP	1.2" wide	
Plug-In Valves*	1/4" NPT	C7	C7M-4303-SP-P	1.2" wide
	3/8" NPT	C7	C7M-4402-SP-P	1.2" wide

\*Not available on C5 Plug-In manifold



## Spacer Plate

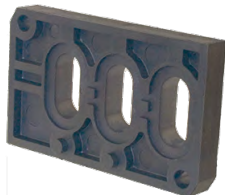

### Spacer Plate

Required on C5 & C7 stacking manifold for mounting adjacent valves with hazardous service electrical operators or when mounting side by side regulators (see page 12).

Hazardous Service solenoids, non Plug-In valves and side by side regulators	C5	C5M-SP4M	0.55" wide
	C7	C7M-SP4M	0.40" wide
Plug-In Valves	C5	C5M-SP4M-P	0.55" wide
	C7	C7M-SP4M-P	0.40" wide

## Isolation Shutoff Plate

### Isolation Shutoff Plate

(Suffix -C7M-IP4M) Available on C7 manifolds to isolate individual valves. By turning the slotted spool in the center of the isolation plate 90° the air flow to the valve can be shutoff facilitate maintenance or testing.



## Bleed Control



### Bleed Control Plates

Bleed Control Plates that provide speed control through metering of the exhausts can be added as an option for any valve stations that require this feature

C5	C5M-BC4M
	C5M-BC4M-P For Low Watt Plug-In valves
C7	C7M-BC4M
	C7M-BC4M-P For Low Watt Plug-In valves
C9	C9M-BC4M
	C9M-BC4M-P For Low Watt Plug-In valves

## Station Blank

C5	C5M-SB4M
C7	C7M-SB4M
C9	C9M-SB4M

### Station Blank

A station blank is used to secure an unused manifold valve station



## Single Station Manifolds



C7

Single Station Manifold  
 C5: C5M-430 (1/4" NPT Ports)  
 C7: C7M-430 (1/4" NPT Ports)  
 C7: C7M-440 (3/8" NPT Ports)  
 C9: C9M-450 (1/2" NPT Ports)



C9

## Multi Pin Connectors, Plug-In Manifold

C5 & C7		
Wire Location DB 25 CONNECTOR		
Pin No.	Wire No.	Function
1	1	Valve 1, SOL A12
14	1	Valve 1, SOL B14
2	2	Valve 2, SOL A12
15	2	Valve 2, SOL B14
3	3	Valve 3, SOL A12
16	3	Valve 3, SOL B14
4	4	Valve 4, SOL A12
17	4	Valve 4, SOL B14
5	5	Valve 5, SOL A12
18	5	Valve 5, SOL B14
6	6	Valve 6, SOL A12
19	6	Valve 6, SOL B14
7	7	Valve 7, SOL A12
20	7	Valve 7, SOL B14
8	8	Valve 8, SOL A12
21	8	Valve 8, SOL B14
9	9	Valve 9, SOL A12
22	9	Valve 9, SOL A14
10	10	Valve 10, SOL A12
23	10	Valve 10, SOL B14
11	11	Valve 11, SOL A12
24	11	Valve 11, SOL B14
12	12	Valve 12, SOL A12
25	12	Valve 1, SOL B14
13	C	COMMON

C9		
Wire Location 19 Pin CONNECTOR		
Pin No.	Wire No.	Function
1	VIOLET	Valve 1, SOL A12
2	RED	Valve 1, SOL B14
3	GREY	Valve 2, SOL A12
4	RED/BLUE	Valve 2, SOL B14
6	GREEN	Valve 3, SOL A12
8	WHITE/GREEN	Valve 3, SOL B14
9	WHITE/YELLOW	Valve 4, SOL A12
10	WHITE/GREY	Valve 4, SOL B14
11	BLACK	Valve 5, SOL A12
13	YELLOW/	Valve 5, SOL B14
14	BROWN	Valve 6, SOL A12
15	BROWN/GREEN	Valve 6, SOL B14
16	WHITE	Valve 7, SOL A12
17	YELLOW	Valve 7, SOL B14
18	PINK	Valve 8, SOL A12
19	GREY/BROWN	Valve 8, SOL B14
5	GRAY/PINK	COMMON
12	BLUE	GROUND
7	GREEN/YEL-LOW	NONE
	BROWN	NONE

Surge Suppression Diode  
 C5, C7 & C9

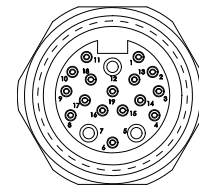
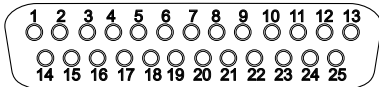
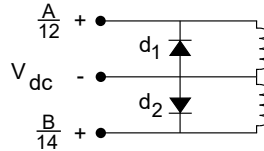

# Regulator Plug-In

## Regulators Plug-In Manifold

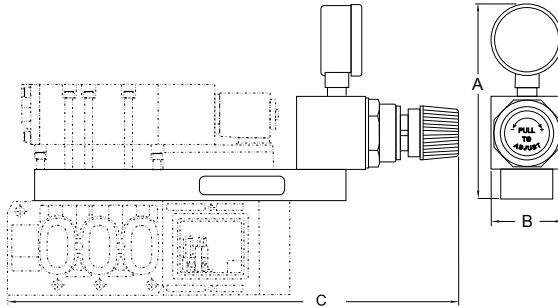

Series	Dimensions		
	A	B	C
C5	3.79" (96.3)	1.25" (31.6)	8.94" (227.1)
C7	4.04" (102.6)	1.5" (38.1)	9.4" (238.8)
C9	5.33" (135.4)	2.14" (54.4)	13.67" (347.2)

Metric dimensions in mm shown in parenthesis.

Series	4 way		5 WAY (Dual pressure 4-Way)		Pressure Range psi
	Non Plug-In	Plug-In	Non Plug-In	Plug-In	
C5	C5AR-4060MG	C5AR-4060MG-P	NA	NA	5-60
	C5AR-4125MG	C5AR-4125MG-P	NA	NA	10-125
	Not Available	Not Available	C7AR-5010MG	C7AR-5010MG-P	1-10
C7	Not Available	Not Available	C7AR-5030MG	C7AR-5030MG-P	3-30
	C7AR-4060MG	C7AR-4060MG-P	C7AR-5060MG	C7AR-5060MG-P	5-60
	C7AR-4125MG	C7AR-4125MG-P	C7AR-5125MG	C7AR-5125MG-P	10-125
	C9AR-4030MG	C9AR-4030MG-P	C9AR-5030MG	C9AR-5030MG-P	3-30
C9	C9AR-4060MG	C9AR-4060MG-P	C9AR-5060MG	C9AR-5060MG-P	5-60
	C9AR-4125MG	C9AR-4125MG-P	C9AR-5125MG	C9AR-5125MG-P	10-125

### Notes:

- 1) Regulator Assembly includes gauge, valve mounting screws and track-gasket.
- 2) For side by side mounting of regulators or for regulators on every station, consult factory.
- 3) Regulators for use with INPilot type valves only.
- 4) For 4-way type regulator, must specify 4-way valve. For 5-way type regulator, must specify 5-way valve. Change first 4 in valve part number to 5, for example, CSG-4332-043 changes to CSG-5332-043.
- 5) Minimum manifold inlet pressure based on valve type.

### SINGLE PRESSURE (4-WAY) REGULATOR FLOW DIAGRAM

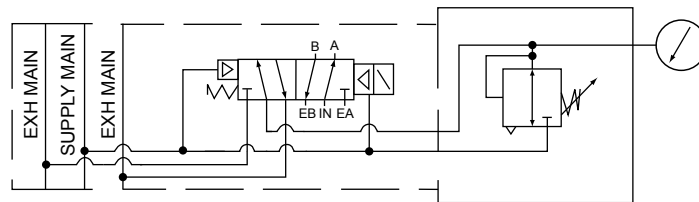

Flow Diagram above shows one single solenoid valve mounted on the Regulator Assembly.

### DUAL PRESSURE (5-WAY) REGULATOR FLOW DIAGRAM

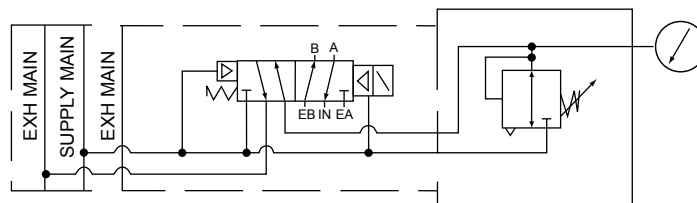

Flow Diagram above shows one single solenoid valve mounted on the Regulator Assembly. Supply Main pressure is supplied to the 'EB' (5) port and Regulated pressure is supplied to the 'EA' (3) port.



Rack Mounted Manifold				
Number of Stations	Manifold Part Number by Port Size			
	3-Way		4-Way	
	Inlet - Exhaust Ports		Inlet - Exhaust Ports	
	1/4" Ports,	3/8" Ports	1/4" Ports	3/8" Ports
2	C5M-3300-2	C7M-3400-2	C5M-4300-2	C7M-4400-2
3	C5M-3300-3	C7M-3400-3	C5M-4300-3	C7M-4400-3
4	C5M-3300-4	C7M-3400-4	C5M-4300-4	C7M-4400-4
5	C5M-3300-5	C7M-3400-5	C5M-4300-5	C7M-4400-5
6	C5M-3300-6	C7M-3400-6	C5M-4300-6	C7M-4400-6
7	C5M-3300-7	C7M-3400-7	C5M-4300-7	C7M-4400-7
8	C5M-3300-8	C7M-3400-8	C5M-4300-8	C7M-4400-8
9	C5M-3300-9	C7M-3400-9	C5M-4300-9	C7M-4400-9
10	C5M-3300-10	C7M-3400-10	C5M-4300-10	C7M-4400-10

## Rack Mount Regulator

### Regulator Rack Manifold

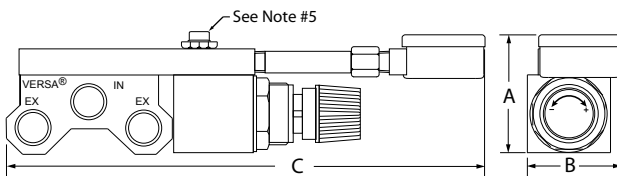

Series	Dimensions		
	A	B	C
C5	2.12" (53.8)	1.25" (31.8)	6.79" (172.5)
C7	2.27" (57.7)	1.7" (42.4)	8.66" (220)

Inch (mm)

4 way		5 WAY (Dual pressure 4-Way)		Pressure Range psi
C5	C7	C5	C7	
C5AR-4010G	C7AR-4010G	C5AR-5010G	C7AR-5010G	1-10
C5AR-4030G	C7AR-4030G	C5AR-5030G	C7AR-5030G	3-30
C5AR-4060G	C7AR-4060G	C5AR-5060G	C7AR-5060G	5-60
C5AR-4125G	C7AR-4125G	C5AR-5125G	C7AR-5125G	10-125

#### NOTES:

- 1) Regulator Assembly includes valve mounting screws and O-rings and can only be mounted on every other station. Alternate regulator assemblies for adjacent stations.
- 2) All valves must be EXPilot type. No auxiliary pilot pressure required (see diagrams).
- 3) Minimum manifold inlet pressure required is based on valve type. See Technical Information page 5.
- 4) C7 only: regulator assembly product numbers listed are for use with Expilot solenoid operated valves only. For pilot or lever operated valves add "P" to the product number shown. FOR EXAMPLE: C7AR-4010GP
- 5) C7 only: assemble the adapter assembly flush in the pilot port of solenoid valve using a 9/16" wrench.



Rack Station Blank

- C5: C5M-SB4
- C7: C7M-SB4
- C9: C9M-SB4



Rack Bleed Control

- C5: C5M-BC4
- C7: C7M-BC4

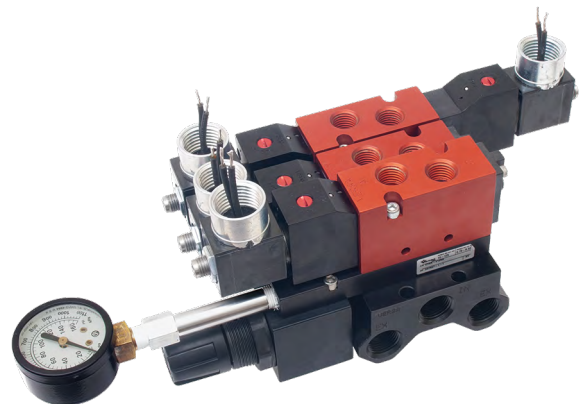

- Shown: 1 Manifold: C7M-4300-3  
 1 Regulator: C7AR-4125G  
 1 Four-Way Valve: CSG-4302-228L-D024  
 1 Four-Way Valve: CSG-4322-228L-D024  
 1 Four-Way Valve: CGG-4322-228L-D024

# Dimensions

## Valves Sideported & Rack Mounted Manifold

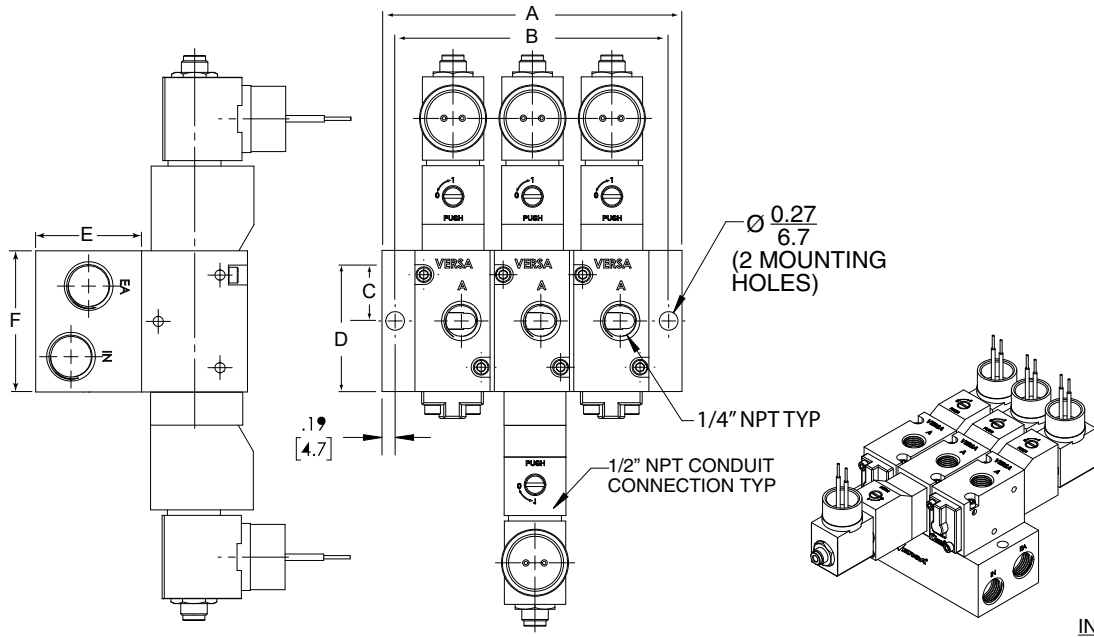

3-WAY C5 & C7 Rack Mounted Manifolds Dimensions

Series	2 Station		3 Station		4 Station		5 Station		6 Station		7 Station		8 Station		9 Station		10 Station		Mounting Holes		Height	Width
	A	B	A	B	A	B	A	B	A	B	A	B	A	B	A	B	A	B	C	D	E	F
C5	2.50	2.19	3.44	3.13	4.38	4.06	5.31	5.0	6.25	5.93	7.19	6.88	8.13	7.81	8.13	9.06	10.0	9.69	1.48	2.27	3.00	1.25
C7	3.13	2.75	4.25	3.88	5.38	5.0	6.50	6.13	7.63	7.25	8.75	8.38	9.88	9.50	11.0	10.63	12.13	11.75	1.0	2.0	3.00	1.50

\* Dimensions: Inches

Rack Mounted Manifold Part Number

Valve Series	Part Number	Manifold Port Size
C5	C5M-3300-(*number of stations)	1/4" NPT
C7	C7M-3400-(*number of stations)	3/8" NPT

\*Indicate number of stations, 2 to 10

**NOTE:** manifolds available with ISO threads, consult factory.

## Valves, Sideported

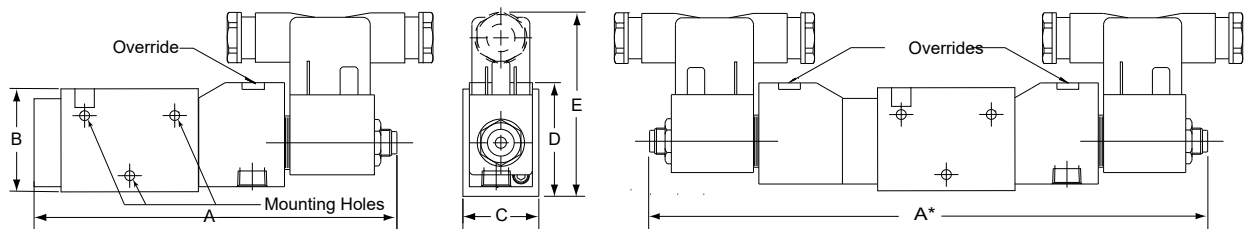

**NOTE:** valves available with ISO threads, consult factory.

3-Way	A	A*	B	C	D	E	Port Size	Mounting Holes Diameter
C5	5.03" (127.7)	7.92" (201.2)	1.25" (31.8)	0.88" (22.4)	1.46" (37.2)	2.54" (64.5)	1/8" NPT (G1/8)	0.144" #8 Screw
C7	5.65" (143.6)	8.55" (217.1)	1.50" (38.1)	1.06" (27.0)	1.59" (40.3)	2.66" (67.5)	1/4" NPT (G1/4)	0.172" #8 Screw

Metric dimensions in mm, shown in parenthesis.

# Valves Sideported & Rack Mounted Manifold

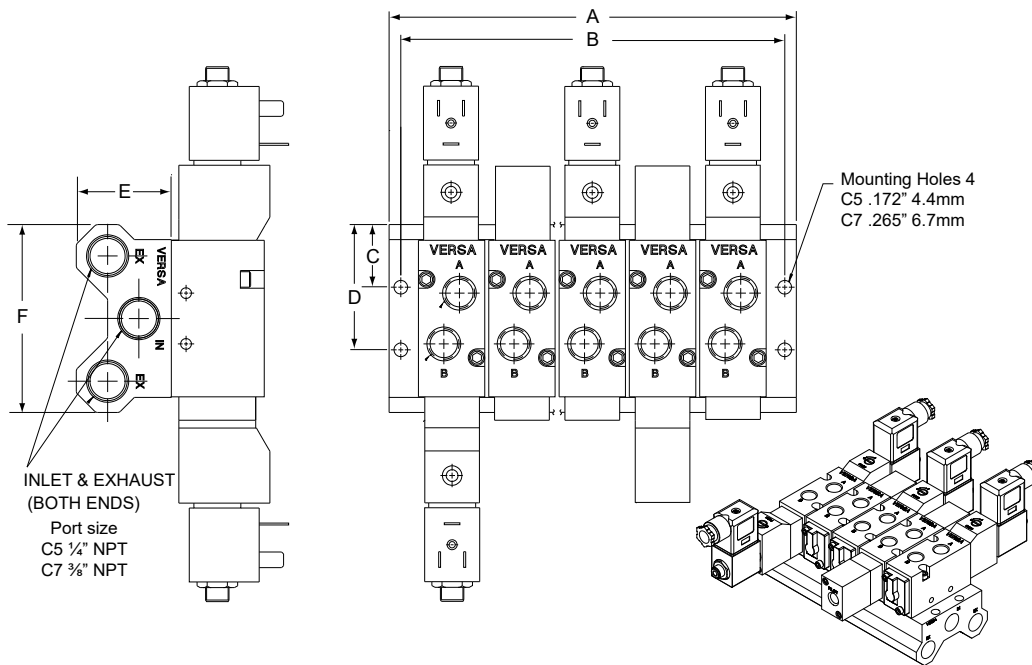

4-WAY C5 & C7 Rack Mounted Manifolds Dimensions																		Mounting Holes		Height	Width	
	2 Station		3 Station		4 Station		5 Station		6 Station		7 Station		8 Station		9 Station		10 Station		C	D	E	F
Series	A	B	A	B	A	B	A	B	A	B	A	B	A	B	A	B	A	B	C	D	E	F
C5	2.50	2.19	3.44	3.13	4.38	4.06	5.31	5.0	6.25	5.93	7.19	6.88	8.13	7.81	8.13	9.06	10.0	9.69	1.48	2.27	3.00	1.25
C7	3.13	2.75	4.25	3.88	5.38	5.0	6.50	6.13	7.63	7.25	8.75	8.38	9.88	9.50	11.0	10.63	12.13	11.75	1.0	2.0	3.00	1.50

\* Dimensions: Inches

Rack Mounted Manifold Part Number		
Valve Series	Part Number	Manifold Port Size
C5	C5M-4300-( <i>*number of stations</i> )	¼" NPT
C7	C7M-4400-( <i>*number of stations</i> )	⅜" NPT

\*Indicate number of stations, 2 to 10

**NOTE:** manifolds available with ISO threads, consult factory.

# Valves, Sideported

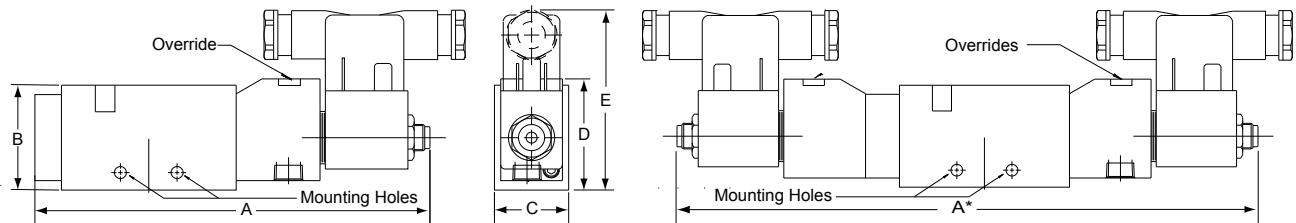

**NOTE:** valves available with ISO threads, consult factory.

4-Way	A	A*	B	C	D	E	Port Size	Mounting Holes Diameter
C5	5.03" (127.7)	7.92" (201.2)	1.25" (31.8)	0.88" (22.4)	1.46" (37.2)	2.54" (64.5)	⅛" NPT (G½)	0.144" #8 Screw
C7	5.65" (143.6)	8.55" (217.1)	1.50" (38.1)	1.06" (27.0)	1.59" (40.3)	2.66" (67.5)	¼" NPT (G¼)	0.172" #8 Screw
C9	7.45" (189)	11.79" (300)	2.25" (57.2)	1.75" (44.5)	2.25" (44)	3.17" (80.5)	½" NPT	0.27" ¼" Screw

Metric dimensions in mm, shown in parenthesis.



# Dimensions

## Valves, Pilot & Manual

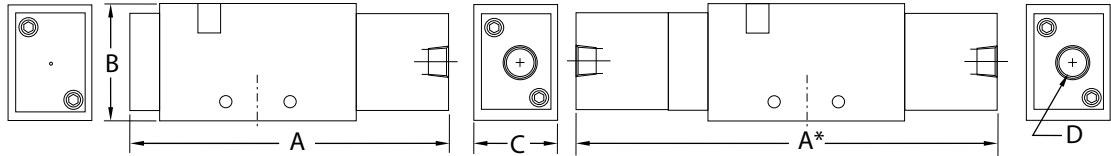

3 Way	A	A*	B	C	D	Inlet, Exhaust, & Cylinder Ports
C5	2.88" (73.2)	4.19" (106.4)	1.25" (31.8)	0.88" (22.2)	1/8" NPT (G1/8)	1/8" NPT (G1/8)
C7	3.06" (73.2)	4.38" (111.3)	1.50" (38.1)	1.06" (27.0)	1/8" NPT (G1/8)	1/4" NPT (G1/4)

Metric dimensions in mm shown in parenthesis.

4 Way	A	A*	B	C	D	Inlet, Exhaust, & Cylinder Ports
C5	3.44" (87.3)	4.75" (120.7)	1.25" (31.8)	0.88" (22.2)	1/8" NPT (G1/8)	1/8" NPT (G1/8)
C7	4.06" (103.2)	5.38" (136.6)	1.50" (38.1)	1.06" (27.0)	1/8" NPT (G1/8)	1/4" NPT (G1/4)
C9	5.88" (149)	7.88" (200)	1.73" (43.9)	2.0" (50.8)	1/8" NPT	1/2" NPT

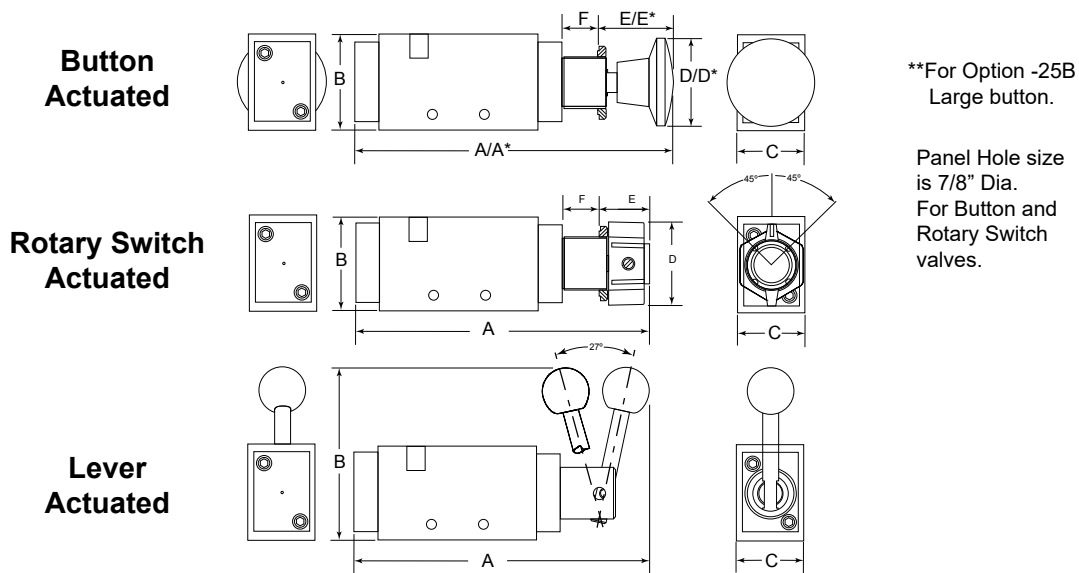

\*\*For Option -25B  
Large button.

Panel Hole size  
is 7/8" Dia.  
For Button and  
Rotary Switch  
valves.

3-Way		A	A*	B	C	D	D** Large Button	E	E*	F	Inlet, Exhaust, & Cylinder Ports
Button Actuated Valves	C5	3.81" (111.0)	4.1" 118.4	1.25" (31.8)	0.88" (22.2)	1.38" (35.1)	1.81" (46.0)	0.88" (22.4)	0.17" (4.3)	0.56" (14.2)	1/8" NPT G1/8
	C7	3.99" (101.3)	4.28" (109)	1.50" (38.1)	1.06" (27.0)	1.38" (35.1)	1.81" (46.0)	0.88" (22.4)	0.17" (4.3)	0.56" (14.2)	1/4" NPT G1/4
Rotary Switch Actuated Valves	C5	3.4" (100.6)	--	1.25" (31.8)	0.88" (22.2)	--	--	0.78" (19.8)	--	2.00" (50.8)	1/8" NPT G1/8
	C7	3.58" (91)	--	1.50" (38.1)	1.06" (27.0)	--	--	0.78" (19.8)	--	2.62" (67.0)	1/4" NPT G1/4
Lever Actuated Valves	C5	3.48" (88.4)	--	2.63" (66.8)	0.88" (22.2)	--	--	--	--	--	1/8" NPT G1/8
	C7	3.04" (77.2)	--	2.75" (65.9)	1.06" (27.0)	--	--	--	--	--	1/4" NPT G1/4

4-Way		A	A*	B	C	D	D** Large Button	E	E*	F	Inlet, Exhaust, & Cylinder Ports
Button Actuated Valves	C5	4.37" (111.0)	4.66" 118.4	1.25" (31.8)	0.88" (22.2)	1.38" (35.1)	1.81" (46.0)	0.88" (22.4)	0.17" (4.3)	0.56" (14.2)	1/8" NPT G1/8
	C7	4.99" (126.8)	5.28" (134.1)	1.50" (38.1)	1.06" (27.0)	1.38" (35.1)	1.81" (46.0)	0.88" (22.4)	0.17" (4.3)	0.56" (14.2)	1/4" NPT G1/4
Rotary Switch Actuated Valves	C5	3.96" (100.6)	--	1.25" (31.8)	0.88" (22.2)	--	--	0.78" (19.8)	--	2.00" (50.8)	1/8" NPT G1/8
	C7	4.58" (116.3)	--	1.50" (38.1)	1.06" (27.0)	--	--	0.78" (19.8)	--	2.62" (67.0)	1/4" NPT G1/4
Lever Actuated Valves	C5	4.04" (102.7)	--	2.63" (66.8)	0.88" (22.2)	--	--	--	--	--	1/8" NPT G1/8
	C7	4.04" (102.7)	--	2.75" (65.9)	1.06" (27.0)	--	--	--	--	--	1/4" NPT G1/4

Metric dimensions in mm shown in parenthesis.

**NOTE:** valves available with ISO threads, consult factory.

# Manifolds, Stacking

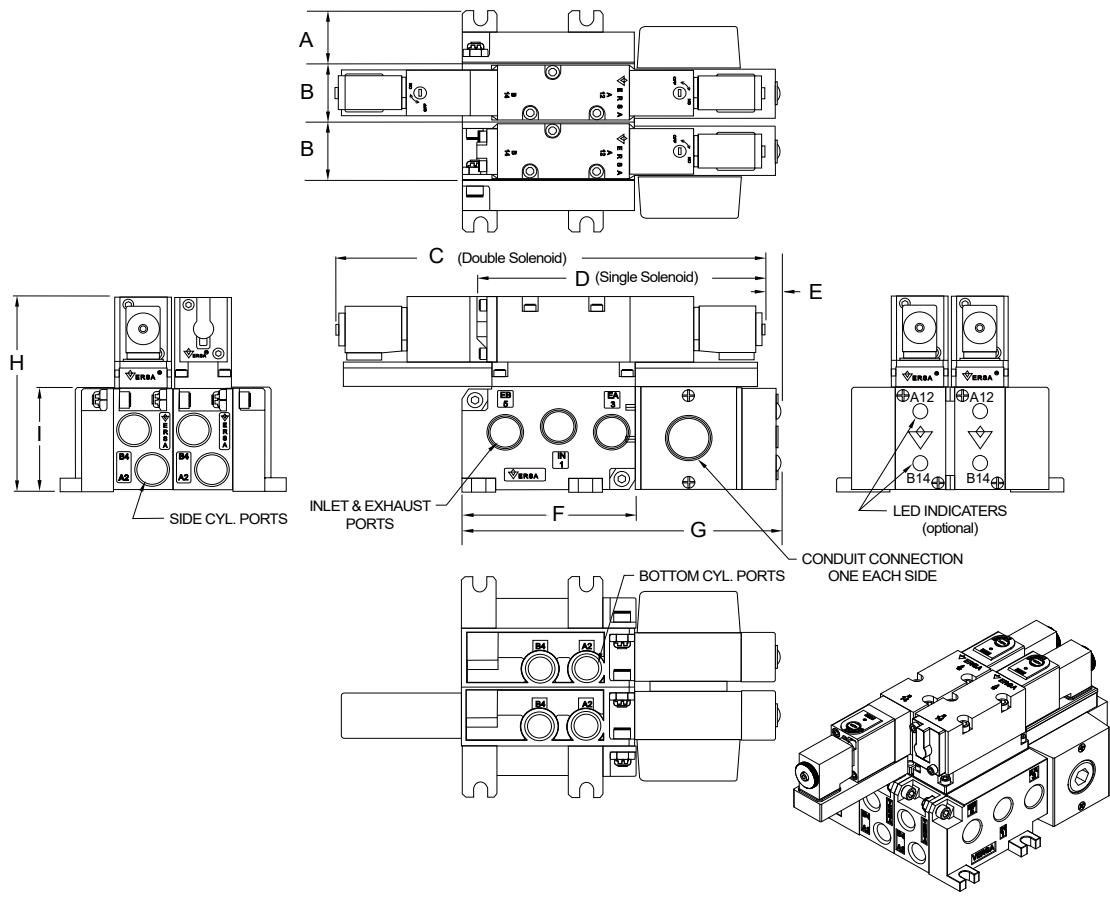

C5, C7 & C9 4-Way Stacking Manifolds Dimensions												
SERIES	A	B	C	D	E	F	G	H	I	Conduit Ports	Inlet Ports	Conduit Hub
C5	1" (25.4)	.95" (24.1)	7.40" (188.1)	4.76" (121.0)	.33" (8.4)	2.60" (66.0)	5.35" (135.9)	3.79" (96.3)	2.00" (50.8)	Side	1/4" NPT	1/2" NPT
										1/8" or 1/4"		
										Bottom		
C7	1" (25.4)	1.12" (28.5)	8.03" (204)	5.39" (136.9)	.33" (8.4)	3.24" (82.4)	6.00" (152.4)	3.75" (82.4)	2.00" (50.8)	Side	3/8" NPT	1/2" NPT
										1/4" or 3/8"		
										Bottom		
C9	1.75" (44.5)	2.18" (55.4)	10.75" (273.1)	7.32" (185.9)	0.25" (6.4)	7.88" (200.2)	NA	7.86" (199.6)	3.20" (81.28)	Side	3/4" NPT	1" NPT
										1/2"		
										Bottom		
										1/2"		

Metric dimensions in mm shown in parenthesis.

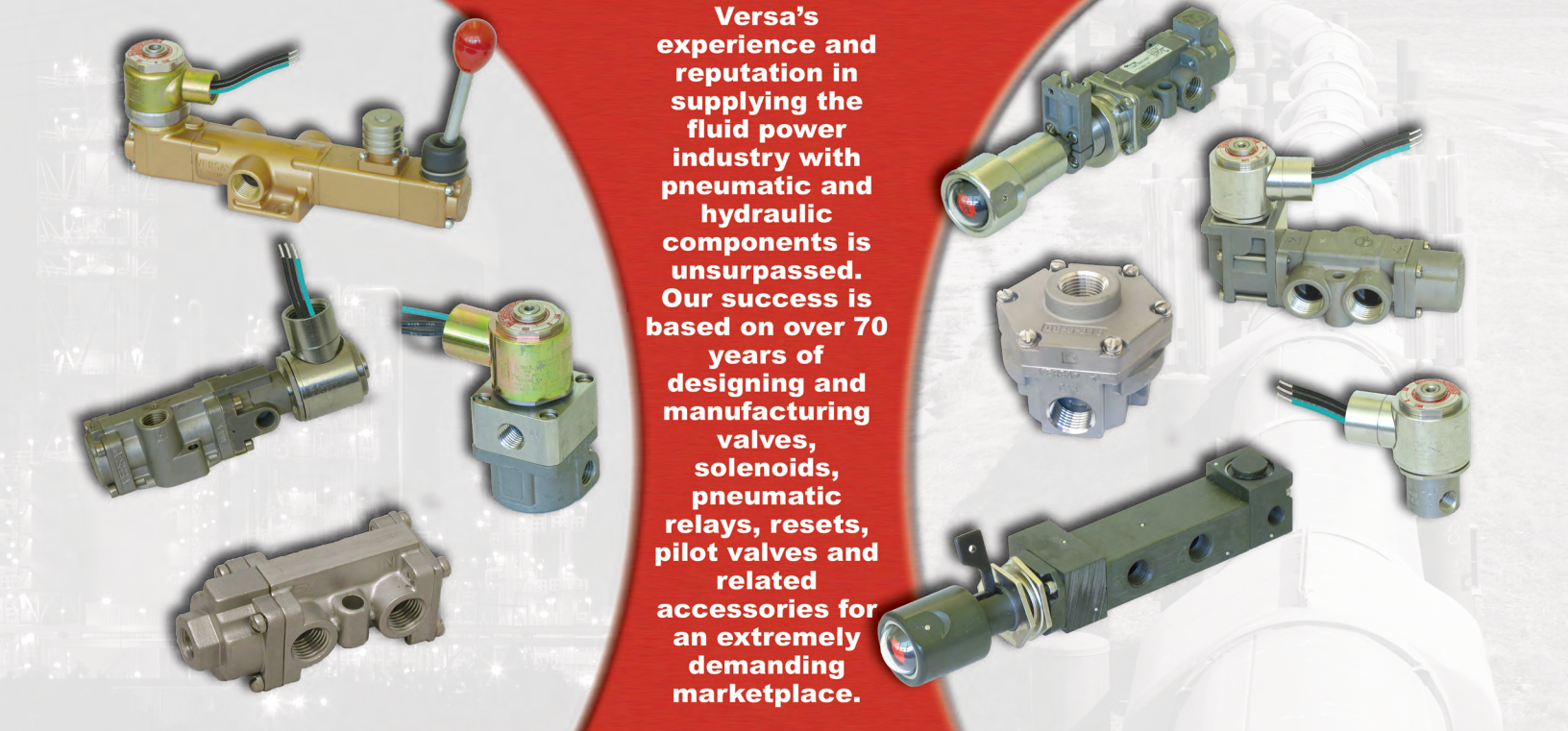

**Versa's  
experience and  
reputation in  
supplying the  
fluid power  
industry with  
pneumatic and  
hydraulic  
components is  
unsurpassed.  
Our success is  
based on over 70  
years of  
designing and  
manufacturing  
valves,  
solenoids,  
pneumatic  
relays, resets,  
pilot valves and  
related  
accessories for  
an extremely  
demanding  
marketplace.**

#### WARNINGS REGARDING THE DESIGN APPLICATION, INSTALLATION AND SERVICE OF VERSA PRODUCTS

The warnings below must be read and reviewed before designing a system utilizing, installing, servicing, or removing a Versa product. Improper use, installation or servicing of a Versa product could create a hazard to personnel and property.

#### DESIGN APPLICATION WARNINGS

Versa products are intended for use where compressed air or industrial hydraulic fluids are present. For use with media other than specified or for non-industrial applications or other applications not within published specifications, consult Versa.

Versa products are not inherently dangerous. They are only a component of a larger system. The system in which a Versa product is used must include adequate safeguards to prevent injury or damage in the event of system or product failure, whether this failure be of switches, regulators, cylinders, valves or any other system component. System designers must provide adequate warnings for each system in which a Versa product is utilized. These warnings, including those set forth herein, should be provided by the designer to those who will come in contact with the system.

Where questions exist regarding the applicability of a Versa product to a given use, inquiries should be addressed directly to the manufacturer. Confirmation should be obtained directly from the manufacturer regarding any questioned application prior to proceeding.

#### INSTALLATION, OPERATION AND SERVICE WARNINGS

Do not install or service any Versa product on a system or machine without first depressurizing the system and turning off any air, fluid, or electricity to the system or machine. All applicable electrical, mechanical, and safety codes, as well as applicable governmental regulations and laws must be complied with when installing or servicing a Versa product.

Versa products should only be installed or serviced by qualified, knowledgeable personnel who understand how these specific products are to be installed and operated. The individual must be familiar with the particular specifications, including specifications for temperature, pressure, lubrication, environment and filtration for the Versa product which is being installed or serviced. Specifications may be obtained upon request directly from Versa. If damages should occur to a Versa product, do not Operate the system containing the Versa product. Consult Versa for technical information.

#### LIMITED WARRANTY DISCLAIMER AND LIMITATION OF REMEDIES

Versa's Series products are warranted to be free from defective material and workmanship for a period of ten years from the date of manufacture, provided said products are used in accordance with Versa specifications. Versa's liability pursuant to that warranty is limited to the replacement of the Versa product proved to be defective provided the allegedly defective product is returned to Versa or its authorized distributor. Versa provides no other warranties, expressed or implied, except as stated above. There are no implied warranties of merchantability or fitness for a particular purpose. Versa's liability for breach of warranty as herein stated is the only and exclusive remedy and in no event shall Versa be responsible or liable for incidental or consequential damages.

Versa Products Company Inc.  
22 Spring Valley Road  
Paramus, New Jersey 07652  
USA  
Phone: 201-843-2400  
Fax: 201-843-2931

Versa BV  
Prins Willem Alexanderlaan 1427  
7321 GB Apeldoorn  
The Netherlands  
Phone: 011-31-55-368-1900  
Fax: 011-31-55-368-1909

[www.versa-valves.com](http://www.versa-valves.com)



[www.versa-valves.com](http://www.versa-valves.com)  
email: [sales@versa-valves.com](mailto:sales@versa-valves.com)